



SEL
MADE IN ITALY

"Experience and Innovations at Your Service"
Totally Designed, Developed and Manufactured in Italy

www.sel-electric.com



Air Insulated Switchgear

TPS up to **24kV**
Medium Voltage Switchgear

TPS 24_{kV} Series

Expanding Range Solutions

and Performances



● General Presentation	5
Experience, Reliability and Continue Innovation	6
Top Features	7
General Description	8
Applications	9
TPS Features	10
Quality	11
Internal Arc Proof Units	12
● TPS Main Characteristics	15
● Main Components	16
Switch Disconnecter	16
Circuit Breaker	18
TCB Circuit Breaker Unique Design	19
Operating Mechanisms	20
TPS Standards	22
Technical Data	23
● Functions	24
Switch Disconnecter Units	SM-SM5-BSM-SMS 24
Cable and Busbar Riser units	CM-CM5-IOC-BM 25
Fuses Switch Disconnecter combination units	FS-FS5-FSM 26
Compact Vacuum CB units	ICBV-ILCBV-ICBVM 27
Vacuum CB units	ICB-SCB-ICBR-SCBR-ICBLT-SCBLT-2ICB-2MCB 28
VTs and CTs units	FIM-FIM5-FIM7-FMM-MTV-MTVS-MTA 32
Cables and Busbars Earthing units	CME-ESM 34
Metering units with Switch Disconnecter	SMM-SMMR 35
Metering units	MBMP-MBMR-MBER-MBMC-MCMP 36
Basic / Optional Equipments	38
● Components	41
Bases and Busbars	42
Keylocks and Padlock Holder	43
Protection Relay	44
Automatic Change Over System (ACO)	45
Fuses	46
Surge Arrester and Measuring Instruments	47
Cables Connections - Connection Height	48
Motorizations - Voltage Indicator - HVSensor	50
Other Accessories	51
Civil Works - Distance from the wall	53
Basement hole for cables incoming/outgoing	54
Hole positioning for floor mounting	55
Standard units Dimensional Data	56
Internal Arc Proof Upward Exhaust units Dimensional Data	58
Internal Arc Proof Downward Exhaust units Dimensional Data	60
Operation Sequences	62



GENERAL PRESENTATION

Experience, Reliability and Continue Innovation	6
Top Features	7
General Description	8
Applications	9
TPS Features	10
Quality	11
Internal Arc Proof Units	12

EXPERIENCE, RELIABILITY AND CONTINUE INNOVATION

SEL S.p.A. has over fifty years of experience in the construction of medium voltage switchgears.

Today SEL S.p.A. offers a comprehensive range of products for medium voltage up to 40.5kV.

SEL S.p.A. offers advanced products that ensure maximum personal safety according to IEC-EN standards, providing internal arc protection as standard.

The TPS series, thanks to the various functional units, allow a wide modularity applicable to all types of requests in MV distribution, with ease of use and compactness.



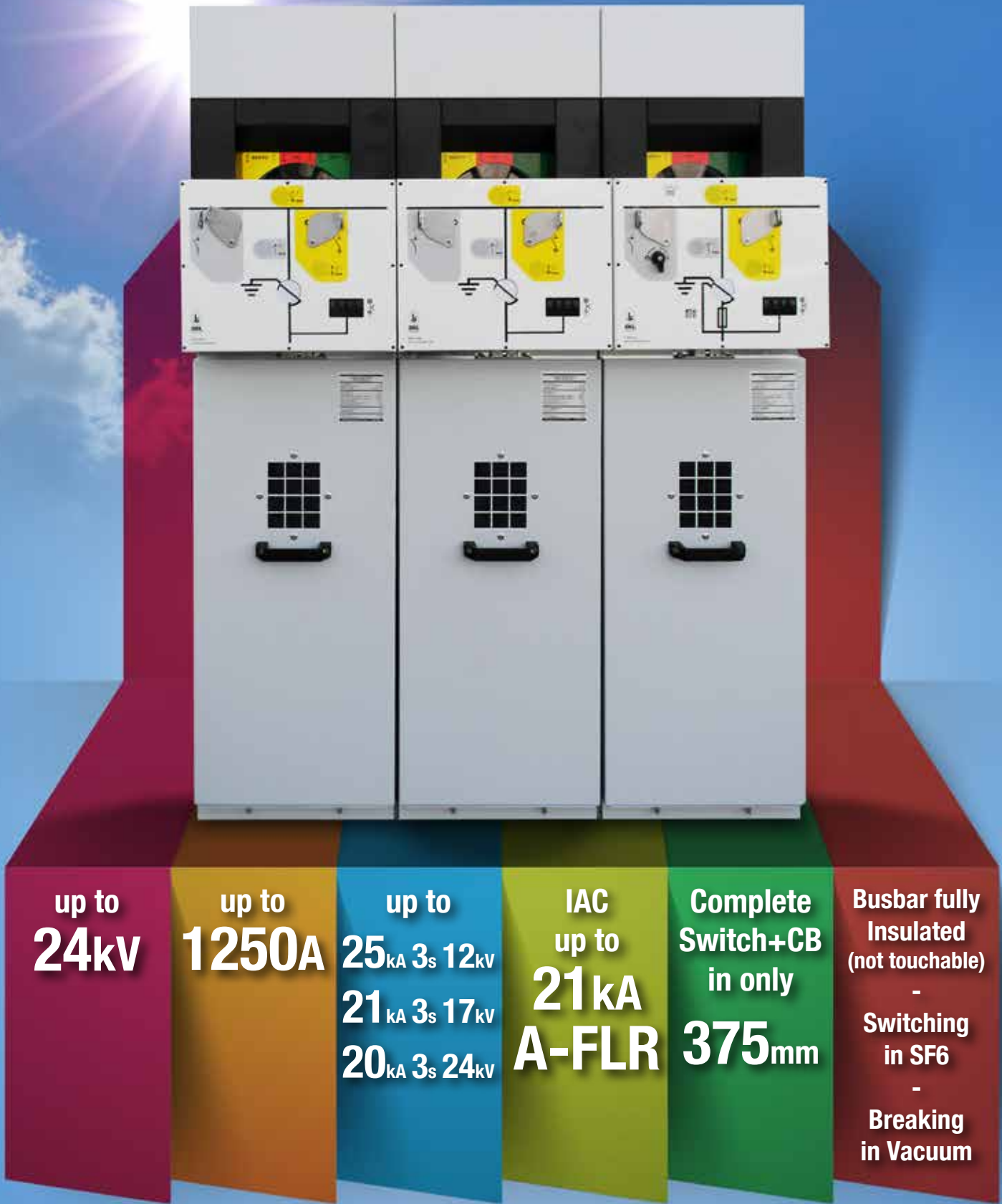

up to
24kV

up to
1250A

up to
25_{kA} 3_s 12kV
21_{kA} 3_s 17kV
20_{kA} 3_s 24kV

IAC
up to
21kA
A-FLR

Complete
Switch+CB
in only
375mm

Busbar fully
Insulated
(not touchable)
-
Switching
in SF6
-
Breaking
in Vacuum

“Experience and Innovation at Your Service”

INTRODUCTION

TPS is a complete unit range which can be equipped with SF6 disconnecter or switch disconnecter and vacuum circuit breaker.

It is suitable for switching, protection and measuring applications in the secondary distribution network up to 24kV.

Modular units are adapted to future ensuring at the same time maximum personnel safety.

CONSTRUCTION CHARACTERISTICS

The switchboard is made of a metal structure composed of galvanized steel sheets that are assembled using rivets and bolts. This structure is built to withstand the electrodynamic stresses during the operation. A switch and earthing switch are fixed to this structure. A switch envelope made of epoxy resin makes the isolation possible between the structure and live parts. An operating mechanism, a mechanical position indicator and a voltage indicator are positioned in the front of the unit. The position of the switch is given by the mechanical indicator whereas the voltage signalling lamp indicates the presence of voltage. Visibility of main contacts can be checked through an inspection window positioned above the operating mechanism. In the front of the unit there is a door giving access to different compartments, e.g. cables, fuses and measurement. When the unit is equipped with a low voltage auxiliary compartment it is situated in its upper part.

SAFETY CHARACTERISTICS

The personnel safety is obtained by means of mechanical

Interlocks as follows:

- When the switch is closed it cannot be earthed and the access to MV cables is prevented.
- When the switch is earthed it is impossible to close the switch but there is a free access to MV cables.
- When the access door to MV cables is opened it is impossible to close the switch.

Metal screens prevent access to live parts during maintenance operations. In addition to the functional interlocks it is possible to lock the switch in three positions "opened, closed, earthed" with the help of keylocks. In case of overpressure the maximum personnel safety is guaranteed by the opening of the safety membrane located on the back side of the switch. In this way the gas is directed to the back of the unit away from the operator.

VERSIONS

TPS is available in the following two series:

- **Standard series: (IAC AFL 12,5kA 1s)**
The series guarantees the internal arc protection on 3 sides up to 12,5kA for 1s.
- **Internal arc proof series: (IAC AFLR 16kA 1s)**
The series guarantees the internal arc protection on 4 sides up to 16kA for 1 s. The robust and reinforced metal structure provides protection against internal arc.
- **Internal arc proof series: (IAC AFLR 21kA 1s)**
The TPS is also available in a version that guarantees the internal arc protection on 4 sides up to 21kA for 1 s. The robust and reinforced metal structure provides protection against internal arc.

APPLICATIONS



TPS is a complete ring main unit range suitable for all the switching operations in 7.2kV, 12kV, 17.5kV, 24kV, secondary distribution network. Operating safely in a distribution network requires different switching points to obtain maximum service continuity in case of fault on the network.

- Power supply companies.
- Power stations.
- Cement industry.
- Automotive industry.
- Iron and steel works.
- Windmills.
- Solar plant.
- Textile, paper and food industries.
- Chemical industry.
- Petroleum industry.
- Pipeline installations.
- Offshore installations.
- Electrochemical plants.
- Petrochemical plants.
- Seaport and shipbuilding industry.
- Diesel power plants.
- Emergency power supply installations.
- Traction power supply systems.
- Stadium and sport center.



TPS FEATURES



FLEXIBILITY

- A wide range of products covering your present and future requirements.
- Modular cubicles adapted to future extensions.
- Possibility to mount auxiliary components under voltage.
- Options to anticipate the telecontrol.



COMPACT DIMENSIONS

- Small dimensions and reduced weights for easier handling and installation.
- Reduced civil works costs.



REDUCED MAINTENANCE

- TPS has long service life.
- Maintenance free live parts which are integrated in vacuum or in a sealed tank of stainless steel.
- Control mechanisms are intended to function with reduced maintenance under normal operating conditions.
- High level of electrical endurance when breaking.



EASY OPERATIONS

- Simple operations.
- All the control operations are carried out from the front by means of a simple devices.



EASY INSTALLATION

- Small dimensions and reduced weights facilitate easy installation.
- Solutions adapted to cable connection.



SAFETY

- During the testing cable operation it is not needed to break the earthing busbar system of the switchgear.
- Interlock operated by earthing switch prevents unsafe operations.
- Additional interlocks to prevent incorrect operations.
- All active parts of the TPS are contained in a sealed tank of stainless steel making it deal for installation in difficult ambient conditions.

All the manufacturing process follows a quality procedure certified by TÜV in accordance with ISO 9001:2015.

The production conforms with the specific quality manual which is updated regularly in the way that it reflects the most recent applicable quality control procedures.

Systematic tests:

Each TPS undergoes a thorough check before leaving the factory. The following routine tests are carried out in order to guarantee the quality, reliability and safety of the product:

- Measurement of the resistance of the main circuits.
- Opening and closing speed measurement on switch, earthing switch and circuit-breaker.
- Operating torque measurement.
- Filling pressure and tightness test.
- Dielectric test.
- Conformity with drawings and diagrams.
- Electrical function test on auxiliary circuits.



INTERNAL ARC PROOF UNITS

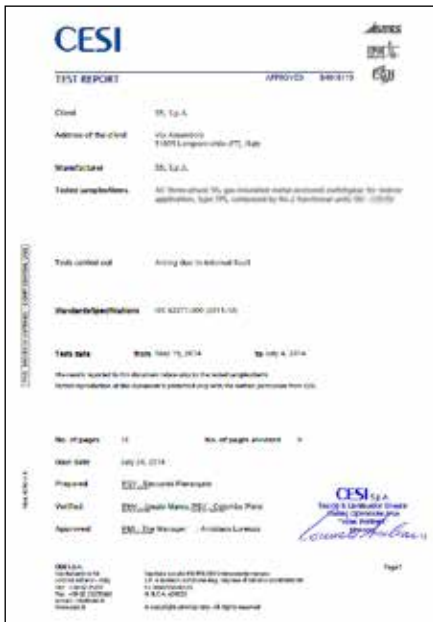

C.E.S.I. test report of Internal Arc Proof A-FLR 21kA 1s

ACCORDING WITH IEC STANDARD 62271-200

Recently an Internal Arc Fault Test up to 21 KA x 1 sec. has been carried out on TPS Switchboards, at CESI Institute in Milan. Test passed successfully as an additional prove of the reliability and safety of the products manufactured by SEL s.p.a. ITALY.

TPS is now available in several options to install standardized internal arc withstand switchboards.

IAC: A-FL 12,5 KA 1 sec.

The operator is safe in case he is in front and lateral of the switchboard

IAC: A-FLR 12,5 KA 1 sec.

The operator is safe in case he is in front, lateral and rear of the switchboard

IAC: A-FLR 16 KA 1 sec.

The operator is safe in case he is in front and lateral of the switchboard

IAC: A-FLR 21 KA 1 sec.

The operator is safe in case he is in front, lateral and rear of the switchboard



Type of Exhaust gas evacuation:

- Downward exhaust.
- Upward exhaust.
- Upward exhaust with gas duct.

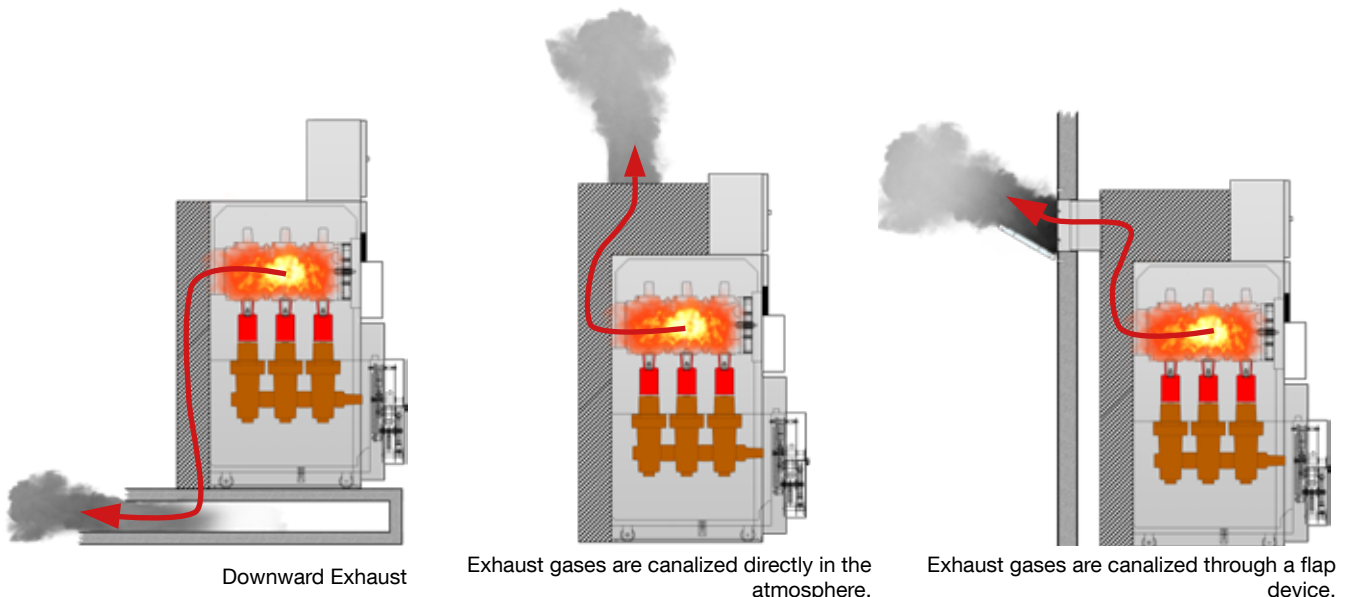

INTERNAL ARC PROOF - THE KINDS OF GASES EXHAUSTED EXPULSION

IAC: A-FL 12.5kA 1s. REAR EXHAUST

Switchgear safe for the personnel placed in front and lateral of it. No specific arrangements have to be provide for installation. Exhaust gas are directed:

- Towards the rear in case of internal switch enclosure fault
- Towards rear and downward in case of arc in the cable zone
- Towards rear and upward in case of arc in the busbar zone

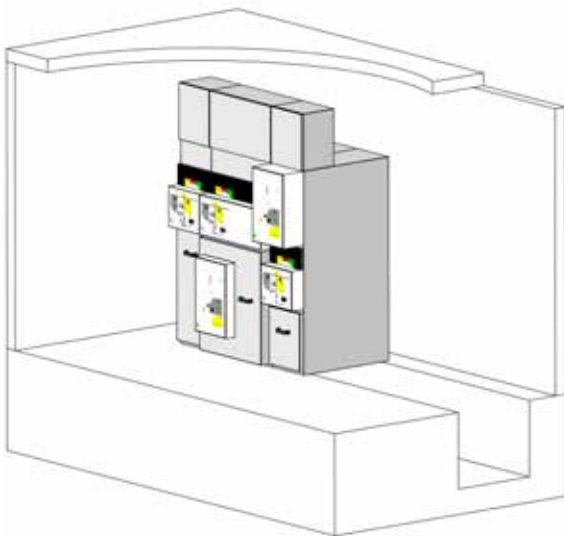

IAC: A-FLR 12.5kA 1s. DOWNWARD EXHAUST

Switchgear safe for the personnel placed in front, lateral and rear side of it. The switchgear is equipped with an additional rear channel (depth 90mm) in order to lead exhaust gas downward in case of arc in all compartments. Trench underneath switchgear has to be 600mm minimum width and 350mm minimum depth.

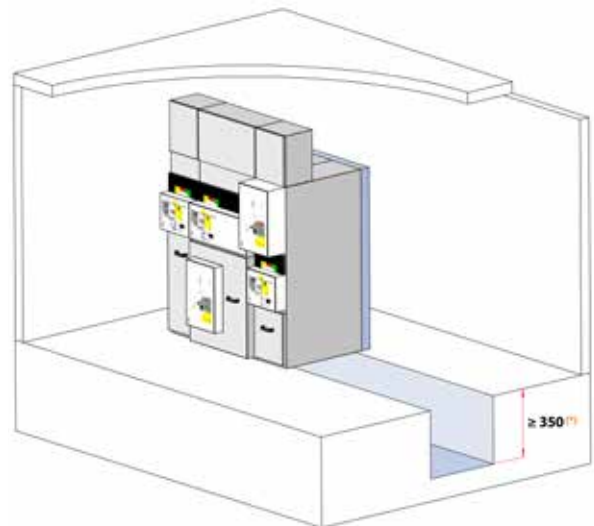

IAC: A-FLR 16 / 21kA 1s. DOWNWARD EXHAUST

Switchgear safe for the personnel placed in front, lateral and rear side of it. The switchgear is equipped with an additional rear channel (depth 90mm) in order to lead exhaust gas downward in case of arc in all compartments. Trench underneath switchgear has to be 930mm minimum width and 500mm minimum depth.

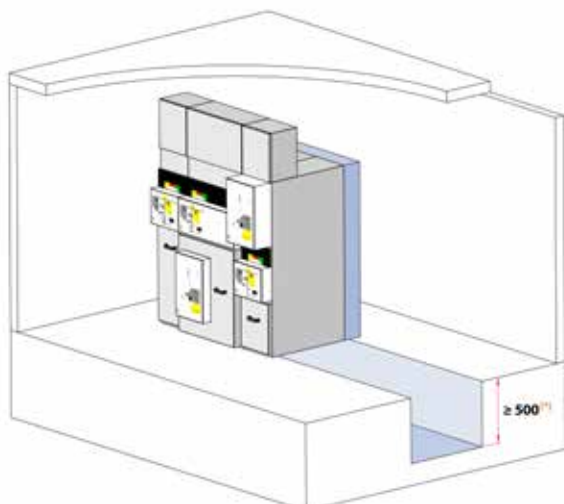

IAC: A-FLR 12,5 / 16 / 21kA 1s. UPWARD EXHAUST

Switchgear safe for the personnel placed in front and lateral of it. The switchgear is equipped with an additional rear channel (depth 180mm) in order to lead exhaust gas upward in case of arc in all compartments. Moreover in the upper part of the switchgear there is a closed additional metal box (to be mount on site at installer care) 400mm height.

The installer can provide a suitable gas duct in order to lead exhaust gas outside to the room.

At the end of gas duct, outside to the room, has to be also provide a suitable termination in order to prevent the entry of water, dust, moisture, animals, etc. and in such case to prevent icing too.

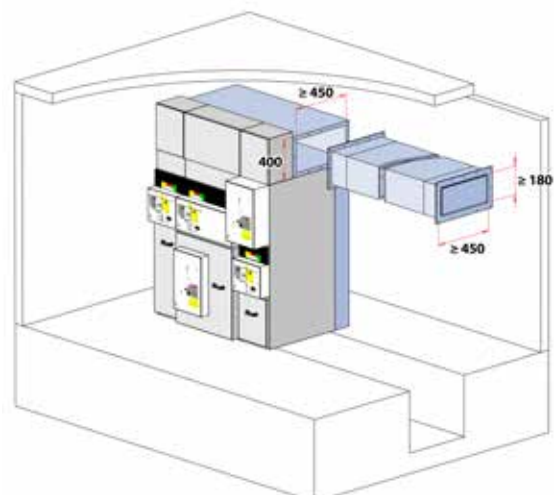



TPS MAIN CHARACTERISTICS

• Main Components	15
Switch Disconnecter	16
Circuit Breaker	16
TCB Circuit Breaker Unique Design	18
Operating Mechanism	19
TPS Standards	20
Technical Data	22
• Functions	24
Switch Disconnectors Units	24
Cables and Busbars Riser Units	25
Fuses Switch Disconnectors combination Units	26
Compact Vacuum CB Units	27
Vacuum CB Units	28
VTs and CTs Units	32
Cables and Busbars Earthing Units	34
Metering Units with Switch Disconnecter	35
Metering Units	36
Basic / Optional Equipments	38

SWITCH DISCONNECTOR



SF6 GAS

The insulation of the switch active parts is obtained by means of sulphur hexafluoride (SF6). This gas has excellent insulating properties; it increases dielectric rigidity in comparison with air and quenches the electric arc. TPS switching parts are contained in epoxy cast resin enclosure filled with SF6 to a relative pressure of 0.4 bar (20°C above sea level).

The use of SF6 insulated equipment offers the following advantages:

- Enhanced electrical endurance.
- Maintenance-free live parts.
- Safe and stable operations.
- Reduced sizes.



SWITCH DISCONNECTOR

The switch disconnecter is made up of an insulating enclosure fixed to the metal structure of the unit. The enclosure filled with SF6 contains the three rotating contacts which carry out the switching operations.

TPS Switch main characteristics:

Gas tightness: The envelope is filled with SF6 gas at a pressure of 0.4 bar.

Safety: In case of any over-pressure, the gas is directed to the rear part of the enclosure by the opening of safety membrane without any risk to the operator.

SWITCH DISCONNECTOR



VISIBILITY OF MAIN CONTACTS

To enhance the safety of the people the TPS switch is equipped with two positions indicators:

1. Mechanical position indication is fixed to the rotating contact shaft.
2. The position of main contacts is clearly visible from the inspection window. In this way the contact position can be checked easily by the operator.

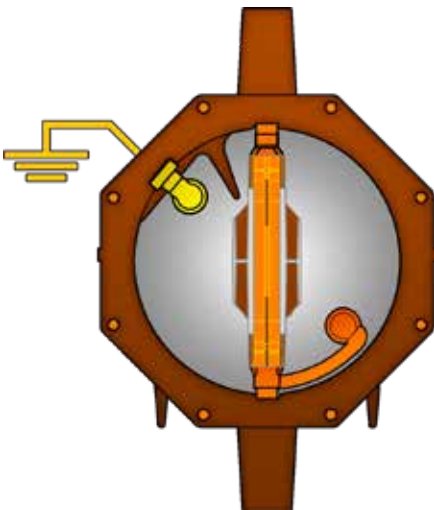

A | CLOSED

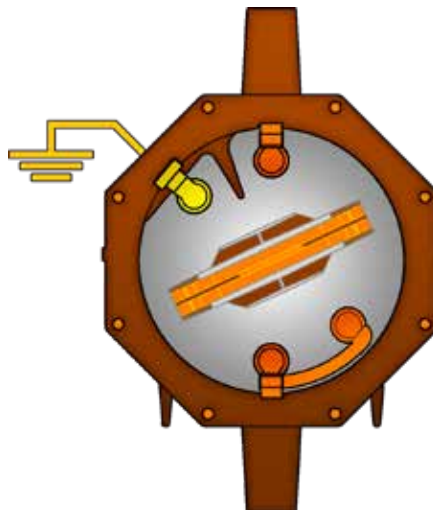

B | OPENED

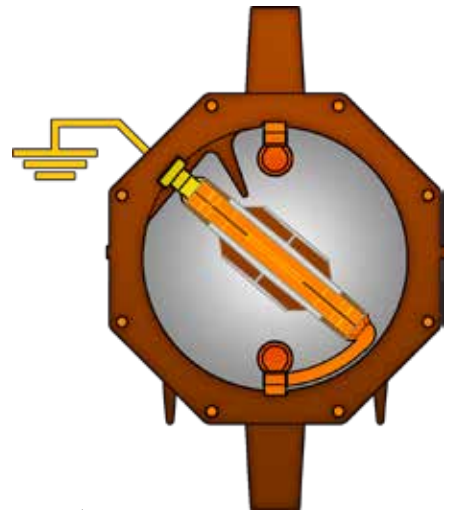

C | EARTHED

CIRCUIT BREAKER

GENERAL INFORMATION

TCB medium voltage vacuum circuit breakers for indoor installation are “sealed for life” pressure systems (IEC 62271-1) and they are manufactured using the separate pole technique. Each pole contains a vacuum interrupter which is incorporated in the resin. This construction technique ensures protection of the vacuum interrupter against impact, dust and condensation phenomena and guarantees the lightning impulse withstand also on the external surface of the vacuum interrupter.



VACUUM TECHNOLOGY

Nowadays the interruption of current in vacuum is recognised as the dominant technology in medium voltage and as a consequence its use is continuously increasing. It is possible to have highly efficient vacuum circuit-breakers with electrical life which is longer than mechanical life, with total respect of environment; but in particular, vacuum circuit-breakers offer enhanced performances thanks to the reduction of arc energy, fast opening time, insulation recovery after overvoltage and reduction of mechanical energy needed for operating mechanism.

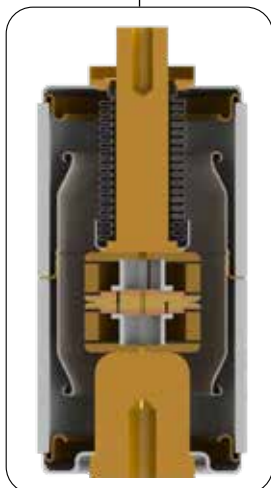

CIRCUIT BREAKER OPERATING MECHANISM

CIRCUIT BREAKER "BUSHING POLE DESIGN"

TCB circuit breaker has a unique and singular design with a bushing pole.⁽¹⁾ Thanks to its particular transmission shaft⁽²⁾ located in the pole central there are no exit /entry contacts placed on the lateral part of the pole. Bushing Pole Design is very easy to be coupled with switch disconnector⁽³⁾ and it gives the possibility to realize very compact switchboards of 375 mm width.⁽⁴⁾ Units called ICBV and ILCBV are very compact and they have a high reliability because the operating mechanism is totally out of the bus bars duct⁽⁵⁾ and the maintenance operations to the Operating mechanism⁽⁶⁾ are very easy to be carried out.

1. Bushing Pole Design.
2. Central transmission shaft.
3. Circuit Breaker/ Switch Disconnector coupling point.
4. Compact dimension. Only 375mm width.
5. Bus bars duct.
6. Easy access inside the CB and Switch operating mechanism for maintenance

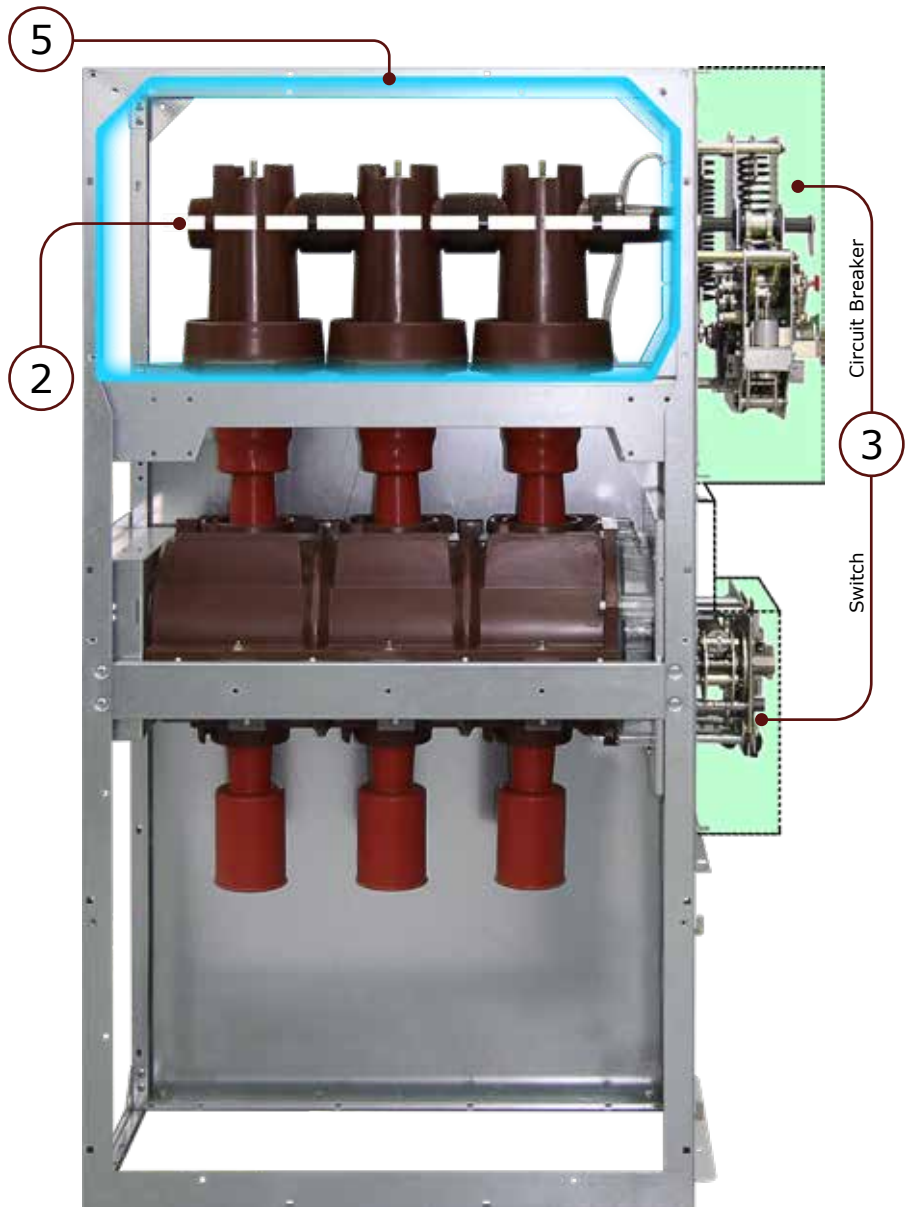
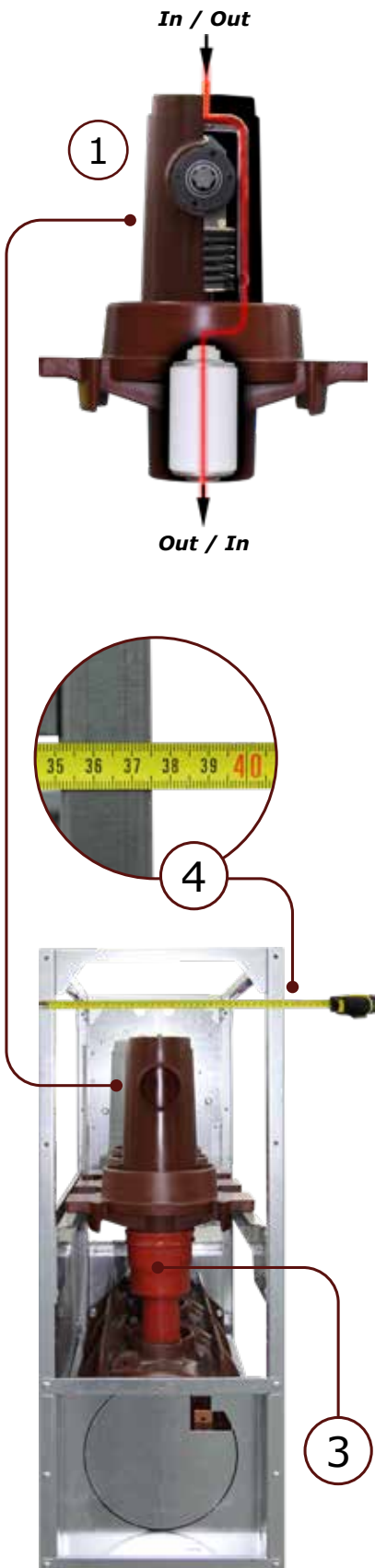

MAIN COMPONENT - OPERATING MECHANISMS



SWITCH DISCONNECTOR OPERATING MECHANISM:

LT Operator independent, operating mechanism which operates under load. Operation energy is provided by a compressed spring which, when released, causes the opening and closing of the device after exceeding a deadlock.

3D Operator independent, energy stored operating mechanism which operates under load. Operation in two steps:

- Operation mechanism charging by lever or motor.
- Stored energy released by opening/closing knob.

NL Operator dependent manual operating mechanism which operates under no-load. Opening and closing by lever.

DNL Operator dependent manual operating mechanism which operates under no-load. Opening and closing by lever (for simultaneous double switching, in 2ICB unit)



EARTHING SWITCH OPERATING MECHANISM

E Operator dependent manual operating mechanism which operates under no-load. (only for earthing disconnectors)

CIRCUIT BREAKER OPERATING MECHANISM

TCB The stored energy type operating mechanism with opening and closing operations independent of the operator allows to carry out a complete cycle O-C-O without spring charging; besides it is suitable for the rapid (0-0,3s-CO-3min-CO) reclosing cycle. Remote control of the circuit-breaker can be provided by means of electrical accessories (e.g. spring charging motor, shunt opening & closing release, undervoltage release in addition to auxiliary contacts).

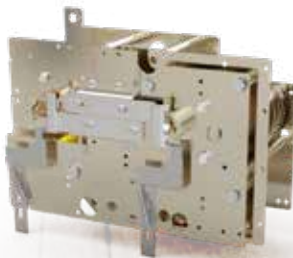

MAIN COMPONENT - OPERATING MECHANISMS

TCB CHARACTERISTICS OF ELECTRICAL ACCESSORIES									
Electrical Auxiliaries		M.U.	Spring charging motor		Shunt Cl. release	Shunt Op. Release	Undervoltage release		Auxiliary Contacts
			Ps	Pc			Ps	Pc	
Charging Time		S	15						
Power Supply	a.c.	V	24-48-110-220 ±10% (50Hz) ; 120-240 ±10% (60Hz)						
	d.c.	V	24-48-110 ±10% (For different Value Contact SEL)						
Power	a.c.	VA	250	50	850	850			
	d.c.	W	250	50	450	450	150	15	
Rated current	a.c. 250V (cos φ 1)	A							15
	a.c. 250V (cos φ 0.6)	A							6

SWITCH-DISCONNECTOR CHARACTERISTICS OF ELECTRICAL ACCESSORIES										
Electrical Auxiliaries		M.U.	3D OPERATING MECHANISM				LT OPERATING MECHANISM			
			Spring charging motor		Shunt Cl. release	Shunt Op. Release	Auxiliary Contacts	Motor		Auxiliary Contacts
			Ps	Pc				Ps	Pc	
Charging Time		S	15					7		
Power Supply	a.c.	V	24-48-110-220 ±10% (50Hz) ; 120-240 ±10% (60Hz)							
	d.c.	V	24-48-110 ±10%							
Power	a.c.	VA	250	50	850	850		800	150	
	d.c.	W	250	50	450 - 650 ^(*)	450 - 650 ^(*)		800	150	
Rated current	a.c. 250V (cos φ 1)	A						15		15
	a.c. 250V (cos φ 0.6)	A						6		6
	d.c. 125V	A						0,6		0,6

(*) For Motorized 3D Operating Mechanism.

NOTE: LT operating mechanism is also used in Vacuum circuit breaker units ICBV and ILCBV. In ICBV unit it is installed in the normal position (with earthing switch on the bottom part); in ICBV unit it is installed in the upside-down position (with earthing switch on the top part). Motorized operating mechanism is not provided for this application.

IEC Standards

TPS is manufactured and tested in conformity with the latest issues of the following IEC standards.

IEC 62271-1	High-voltage switchgear and controlgear - Part 1: Common specifications for alternating current switchgear and controlgear
IEC 62271-200	High-voltage switchgear and controlgear - Part 200: AC metal-enclosed switchgear and controlgear for rated voltages above 1 kV and up to and including 52 kV
IEC 62271-100	High-voltage switchgear and controlgear - Part 100: Alternating current circuit-breakers
IEC 62271-103	High-voltage switchgear and controlgear - Part 103: Switches for rated voltages above 1 kV up to and including 52 kV
IEC 62271-102	High-voltage switchgear and controlgear - Part 102: Alternating current disconnectors and earthing switches
IEC 62271-105	High-voltage switchgear and controlgear - Part 105: Alternating current switch-fuse combinations for rated voltages above 1 kV up to and including 52 kV
IEC 62271-206	High-voltage switchgear and controlgear - Part 206: Voltage presence indicating systems for rated voltages above 1 kV and up to and including 52 kV
IEC 62271-304	High-voltage switchgear and controlgear - Part 304: Design classes for indoor enclosed switchgear and controlgear for rated voltages above 1 kV up to and including 52 kV to be used in severe climatic conditions
IEC 62271-307	High-voltage switchgear and controlgear - Part 307: Guidance for the extension of validity of type tests of AC metal and solid-insulation enclosed switchgear and controlgear for rated voltages above 1 kV and up to and including 52 kV
IEC 60529	Degrees of protection provided by enclosures (IP Code)
IEC 60060-1	High-voltage test techniques - Part 1: General definitions and test requirements
IEC 60376	Specification of technical grade sulfur hexafluoride (SF ₆) for use in electrical equipment
IEC 62271-4	Handling procedures for sulphur hexafluoride (SF ₆) and its mixtures
IEC 60255	Measuring relays and protection equipment
IEC 61869-2	Instrument transformers - Part 2: Additional requirements for current transformers
IEC 61869-3	Instrument transformers - Part 3: Additional requirements for inductive voltage transformers
IEC 60044-8	Instrument transformers - Part 8: Electronic current transformers
IEC 60282-1	High-voltage fuses - Part 1: Current-limiting fuses
DIN 43625	High-voltage fuses; Rated voltage 3,6 to 36 kV; Fuse-Links
EN 50181	Plug-in type bushings above 1 kV up to 52 kV and from 250 A to 2,50 kA for equipment other than liquid filled transformer
CEI 0-16	Reference technical rules for the connection of active and passive consumers to the HV and MV electrical networks of distribution Company

SWITCHGEARS MAIN CHARACTERISTICS						
		kV	7,2	12	17,5	24
Altitude	IEC 62271-1	m	<1000 (for different value contact SEL)			
Ambient air temperature	IEC 62271-1	°C	-5 ÷ 40			
Relative humidity		%	95			
Insulation Rated Voltage		kV	7,2	12	17,5	24
Rated Voltage		kV	7,2	12	17,5	24
Lightning impulse withstand voltage between phases and towards the ground		kV	60	95	95	125
Lightning impulse withstand voltage across the isolating distance		kV	70	110	110	145
Power frequency withstand voltage between the phases		kV	20	28	38	50
Power frequency withstand voltage across the isolating distance		kV	23	32	45	60
Rated Frequency		Hz	50 - 60			
Rated Current	Switch disconnecter		200 - 630			
Rated Current	Vacuum Circuit Breaker		250 - 400 - 630 - 1250			
Rated short time withstand current I_k		kA	up to 25			
Rated peak withstand current I_p (making capacity)		kA	50Hz 2,5 x I_k - 60Hz 2,6 I_k			
Rated duration of short circuit t_k		s	1 - 3			
Degree of protection on front face		IP	3X			
Degree of protection on electrical MV circuits		IP	20			
Internal Arc classification IAC A-F; FL; FLR; including cables box	IEC 62271-200	kA x s	up to 21 1s			

MAIN CHARACTERISTICS (SWITCH DISCONNECTOR - DISCONNECTOR - CIRCUIT BREAKER)						
		kV	7,2	12	17,5	24
Mechanical operation	Switch disconnecter IEC 62271-103		1.000 operations / Class M1			
Electrical operation	Switch disconnecter IEC 62271-103		100 breaks at I_n p.f.=0,7 / Class E3			
Electrical operation	Switch disconnecter IEC 62271-103		making capacity 5 / Class E3			
Mechanical operation	Disconnecter IEC 62271-102		1.000 operations / Class M1			
Mechanical operation	Earthing switch IEC 62271-102		1.000 operations / Class M0			
Electrical operation	Earthing switch IEC 62271-102		making capacity 5 / Class E2			
Mechanical operation	Circuit breaker IEC 62271-100		2000 operations / Class M1 - 10.000 operations / Class M2			
Electrical operation	Circuit breaker IEC 62271-100		E1 - E2			
Breaking Capacity	Circuit breaker IEC 62271-100	kA	25		21	
Making Capacity	Circuit breaker IEC 62271-100	kA	50Hz 2,5 x I_k - 60Hz 2,6 I_k			
Break Time Vacuum Circuit Breaker	Circuit breaker IEC 62271-100	ms	≤ 70			
Rated operating sequence	Circuit breaker IEC 62271-100		0 - 0,3s - CO - t - CO			
Making & breaking on fuse-switch	IEC 62271-105	kA rms	25		20	
Breaking at rated transfer current $I_{transfer}$	IEC 62271-105	A	1800		1400	
Mainly active load breaking current	Switch disconnecter IEC 62271-103	A	630			
Close loop breaking current	Switch disconnecter IEC 62271-103	A	630			
Cable charging breaking current	Switch disconnecter IEC 62271-103	A		32		16
Line charging breaking current	Switch disconnecter IEC 62271-103	A		32		10
Earth fault breaking current	Switch disconnecter IEC 62271-103	A		57		32
No load transformer breaking current	Switch disconnecter IEC 62271-103	A		6,3		

SWITCH DISCONNECTOR UNITS

SM - SWITCH DISCONNECTOR UNIT

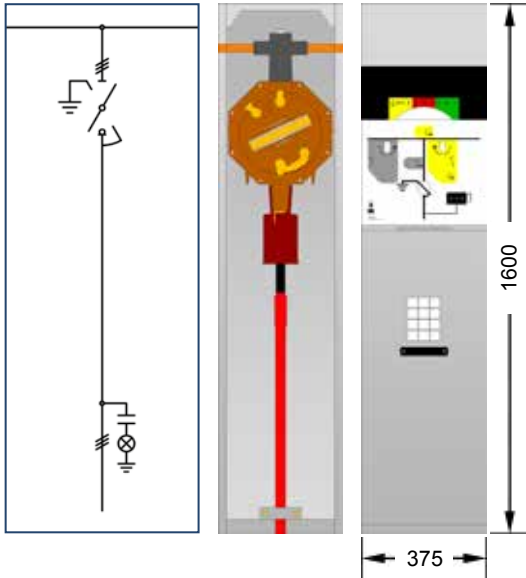

SM5 - SWITCH DISCONNECTOR UNIT

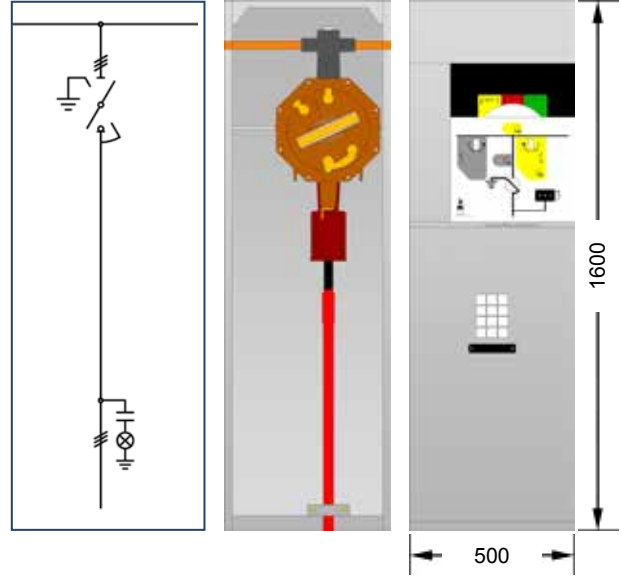

BSM - BUSBAR RISER WITH SWITCH DISCONNECTOR

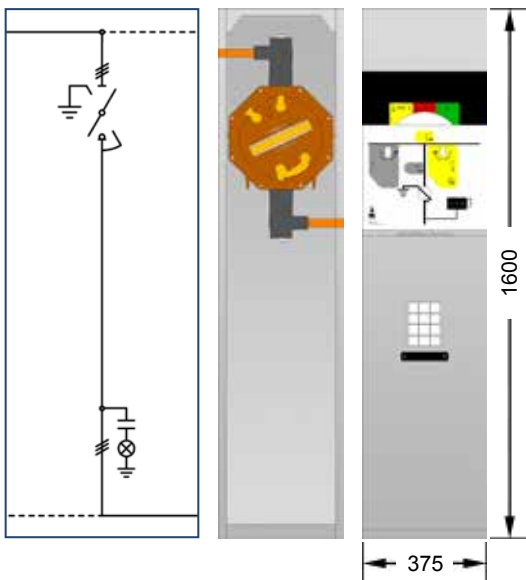

SMS - SURGE ARRESTER UNIT WITH SWITCH DISCONNECTOR

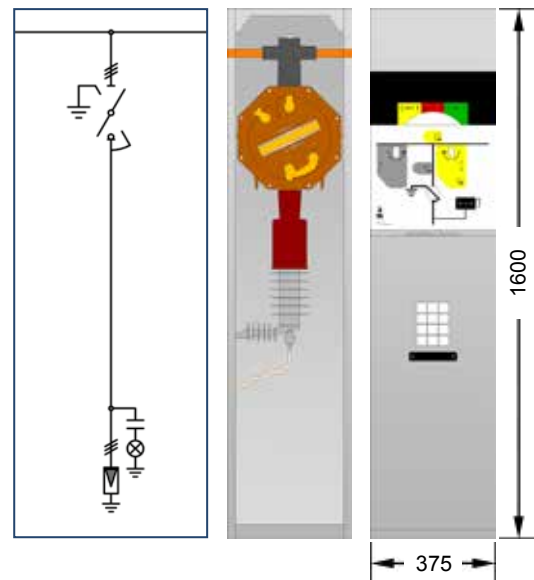

CABLE AND BUSBAR RISER UNITS

CM - CABLE RISER UNIT

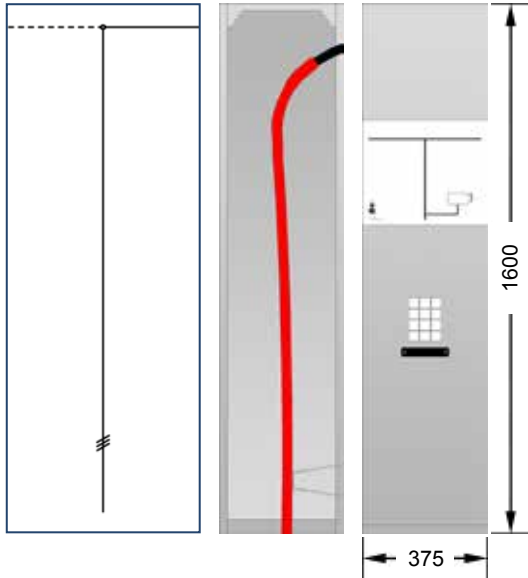

CM5 - CABLE RISER UNIT

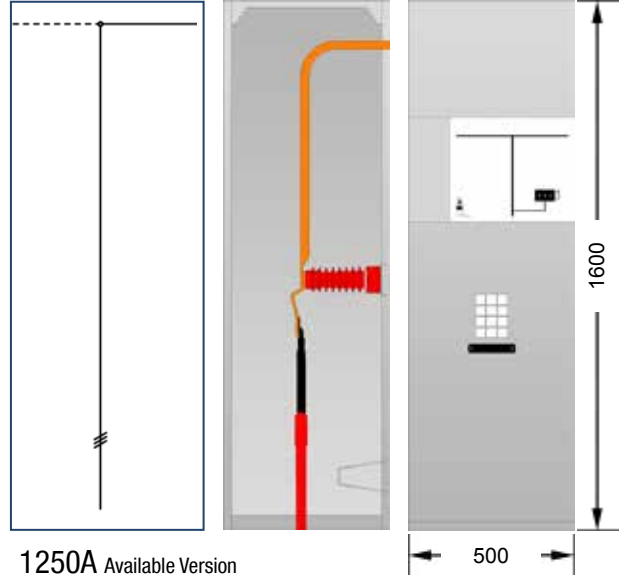

IOC - INCOMING/OUTGOING CABLES UNIT

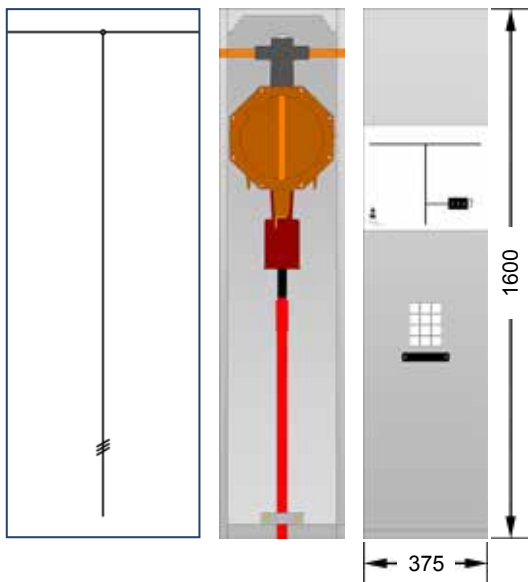

BM - BUSBAR RISER UNIT

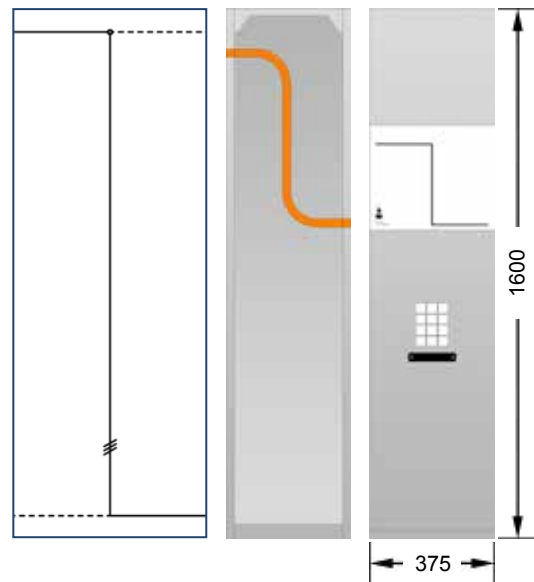

FUSE-SWITCH DISCONNECTOR COMBINATION UNITS

FS - FUSE-SWITCH DISCONNECTOR COMBINATION UNIT

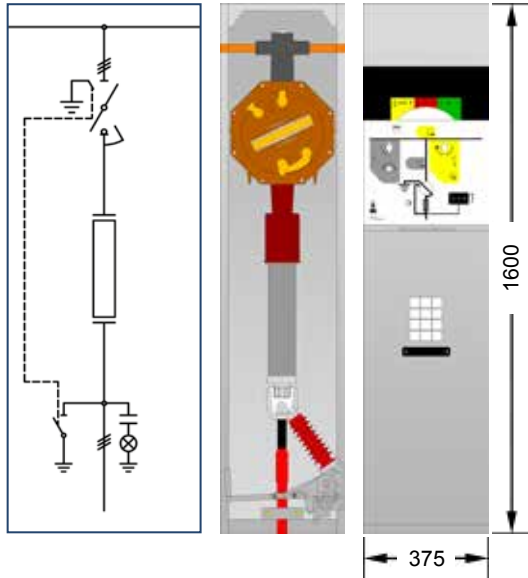

FS5 - FUSE-SWITCH DISCONNECTOR COMBINATION UNIT

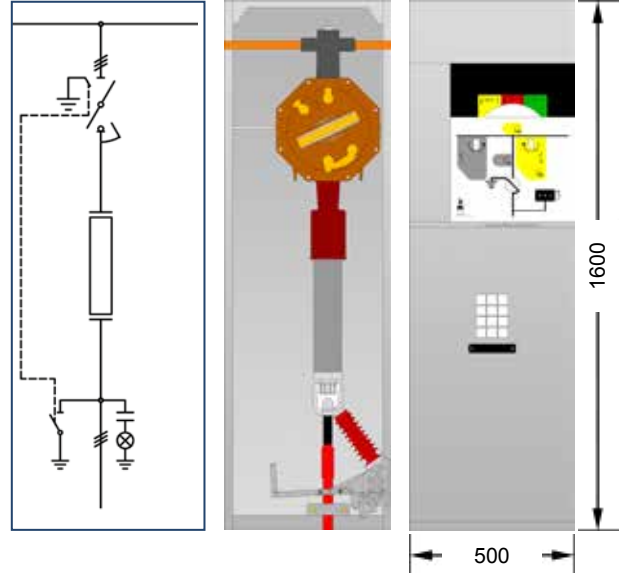

FSM - FUSE-SWITCH DISCONNECTOR COMBINATION UNIT AND MEASUREMENT

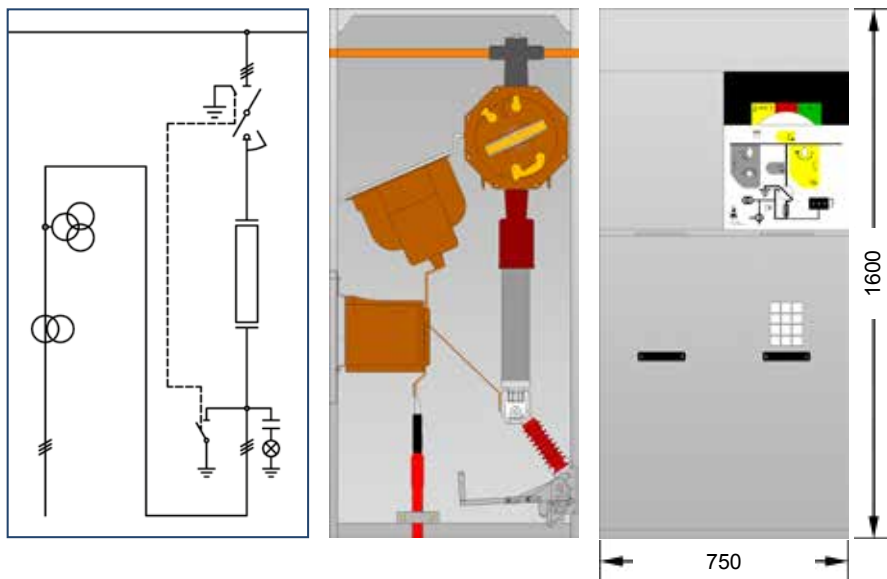

Phase-To-Phase VTs Up to 12kV.
For installation VTs Phase-To-Phase over 12kV Contact SEL.

COMPACT VACUUM CIRCUIT BREAKER UNITS

ICBV - VACUUM CIRCUIT BREAKER UNIT WITH SWITCH-DISCONNECTOR

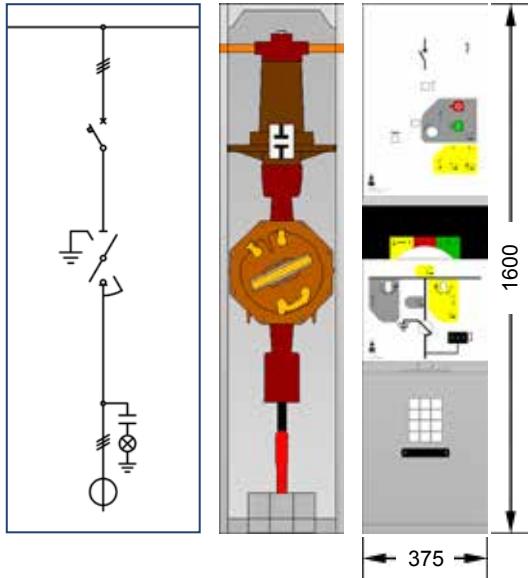

ILCBV - LOWER INCOMING VACUUM CIRCUIT BREAKER UNIT WITH SWITCH-DISCONNECTOR

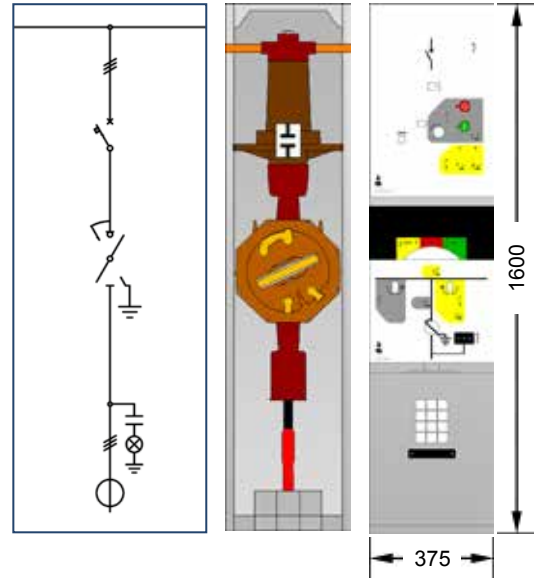

ICBVM - VACUUM CIRCUIT BREAKER UNIT WITH SWITCH-DISCONNECTOR, CT'S AND VT'S - UP TO 17,5kV

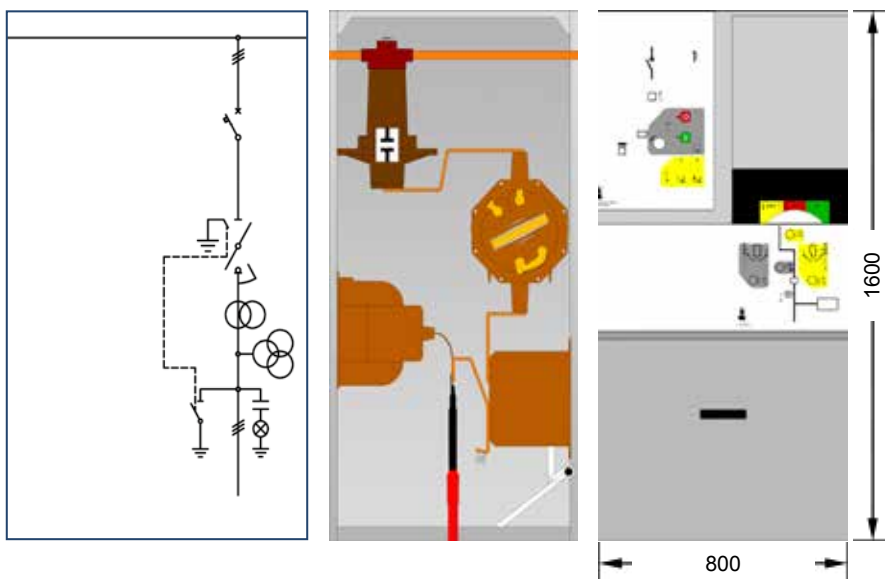

VACUUM CIRCUIT BREAKER UNITS

ICB - CIRCUIT BREAKER UNIT WITH DISCONNECTOR

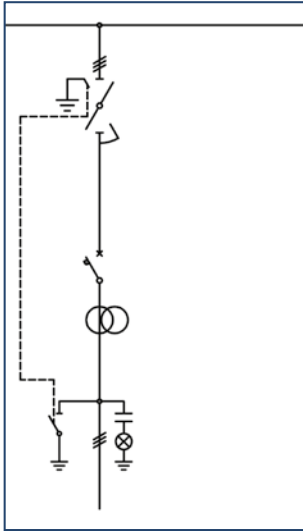

1250A Available Version

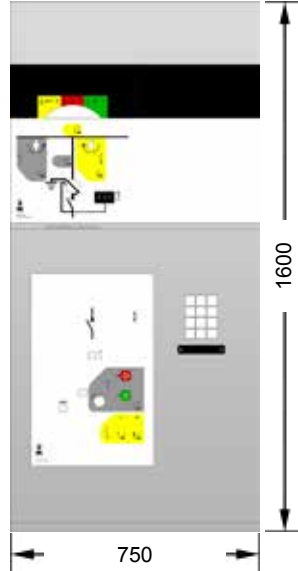
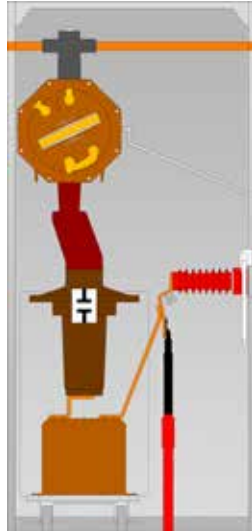

SCB - CIRCUIT BREAKER UNIT WITH SWITCH-DISCONNECTOR

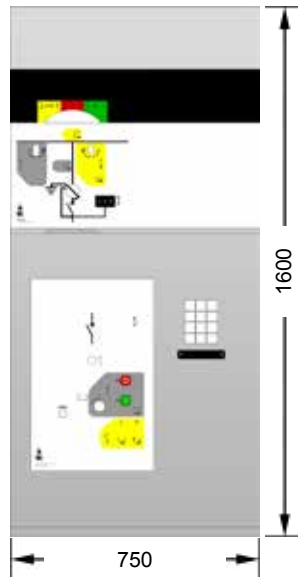
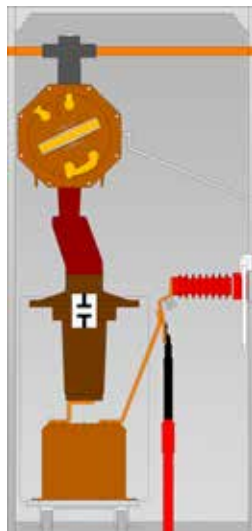
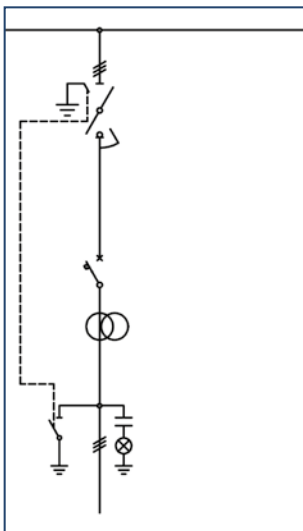

VACUUM CIRCUIT BREAKER UNITS

ICBR - CIRCUIT BREAKER UNIT WITH DISCONNECTOR AND BUSBAR RISER

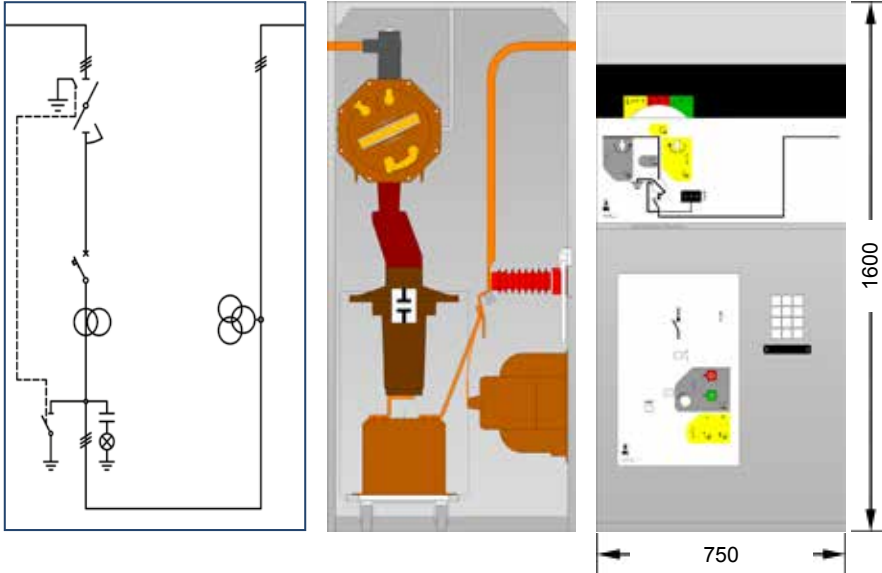

SCBR - CIRCUIT BREAKER UNIT WITH SWITCH-DISCONNECTOR AND BUSBAR RISER

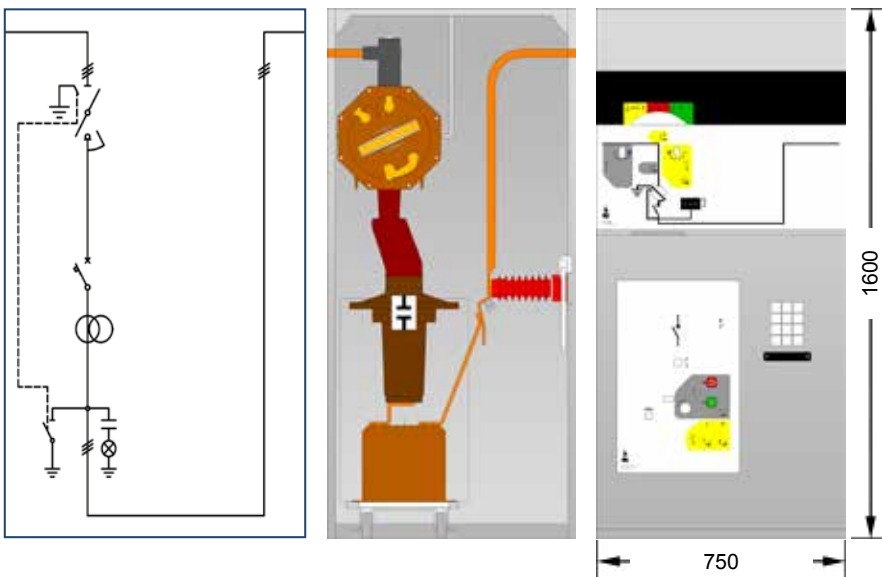

VACUUM CIRCUIT BREAKER UNITS

ICBLT - CIRCUIT BREAKER UNIT WITH DISCONNECTOR AND LATERAL OUTGOING BUSBAR

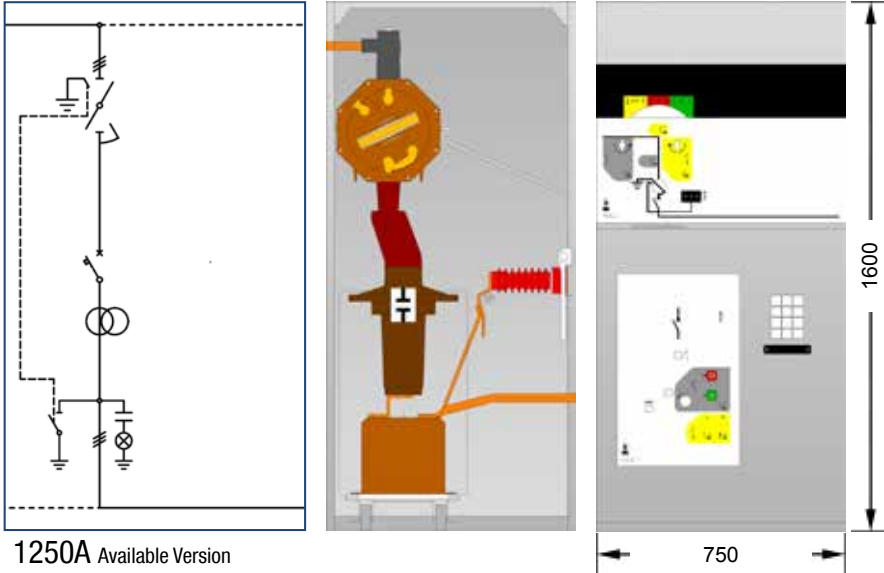

1250A Available Version

SCBLT - CIRCUIT BREAKER UNIT WITH SWITCH-DISCONNECTOR AND LATERAL OUTGOING BUSBAR

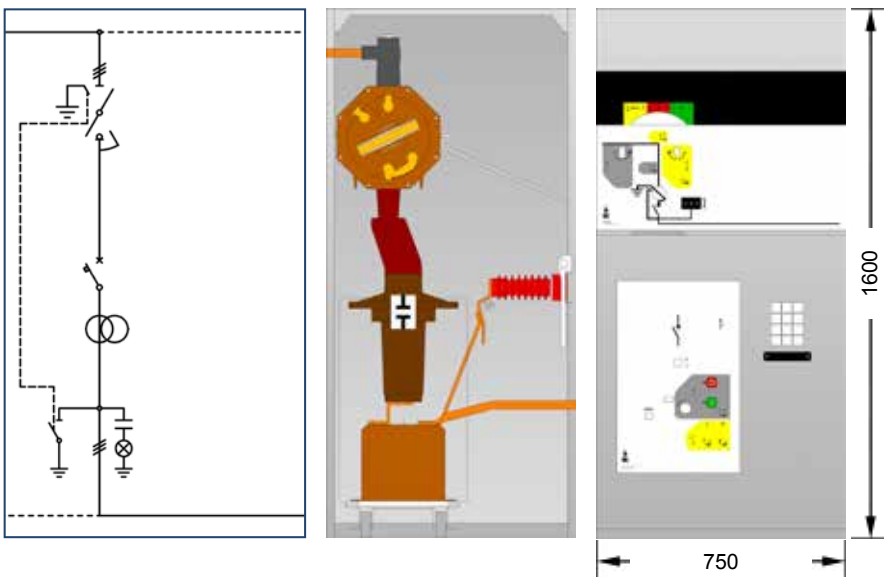

VACUUM CIRCUIT BREAKER UNITS

2ICB - CIRCUIT BREAKER UNIT WITH DOUBLE DISCONNECTOR

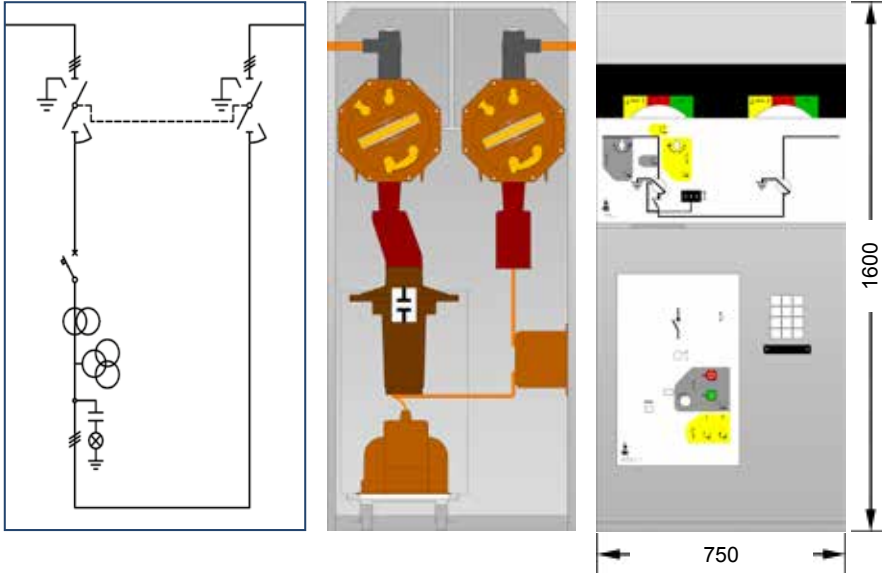

2MCB - CIRCUIT BREAKER UNIT WITH DOUBLE SWITCH-DISCONNECTOR

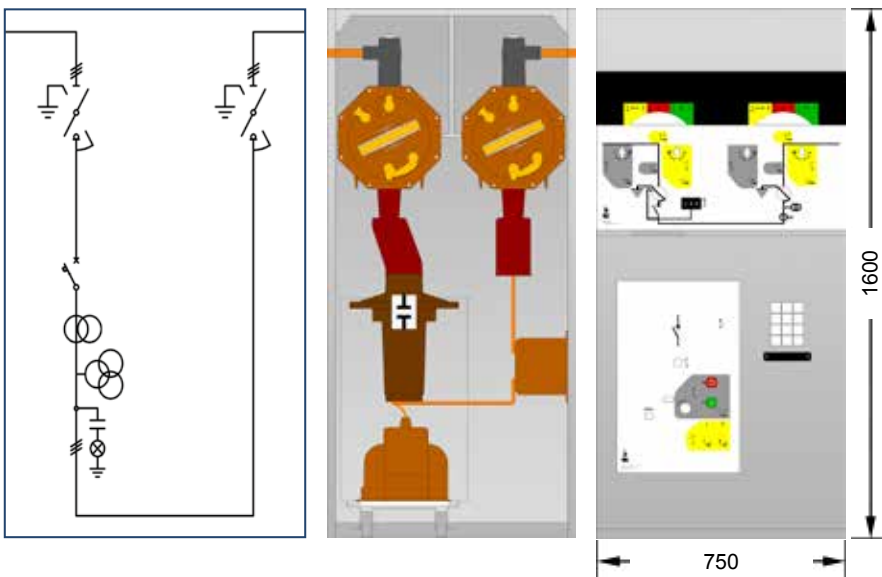

VT'S AND CT'S UNITS

FIM - VT UNIT WITH DISCONNECTOR AND FUSES (375MM)

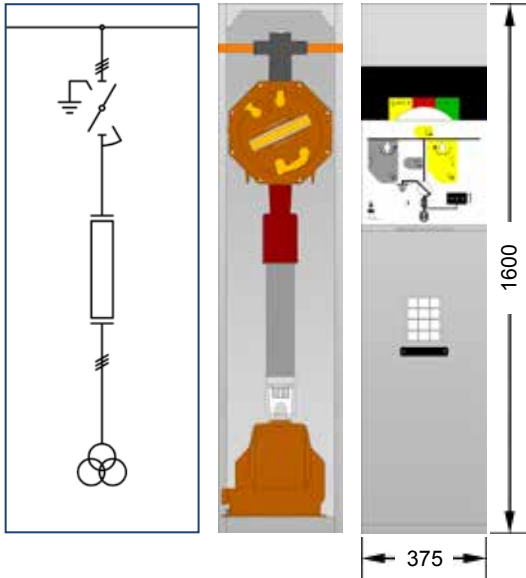

2 VTs Phase-To-Phase only Up to 12kV

FIM5 - VT UNIT WITH DISCONNECTOR AND FUSES (500MM)

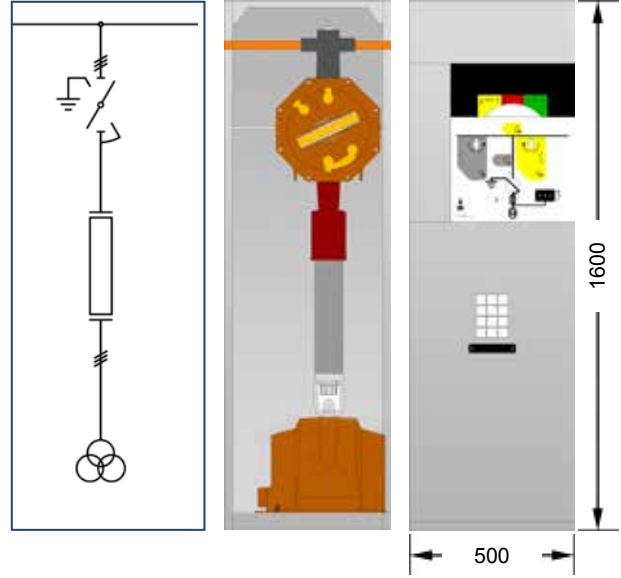

FIM7 - VT UNIT WITH DISCONNECTOR AND FUSES (750MM)

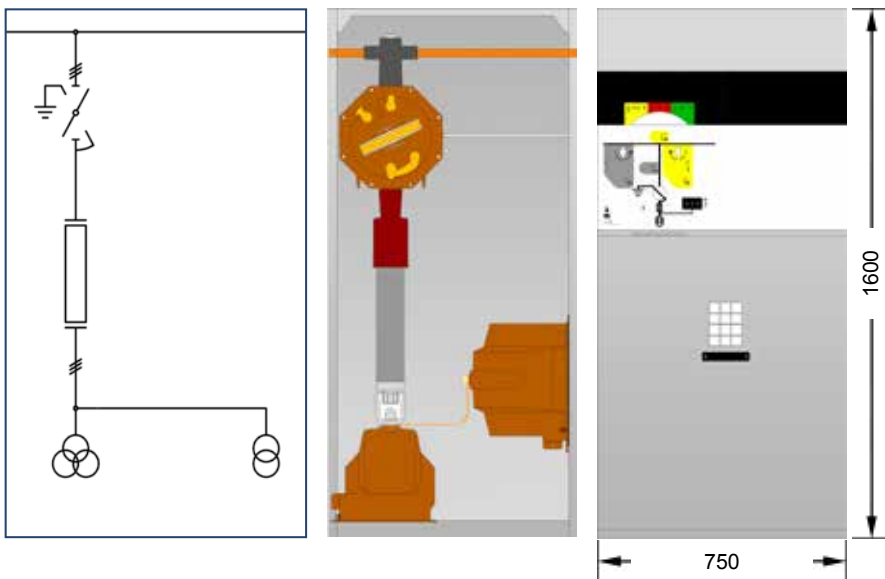

Max 2 VTs Phase-To-Phase + 3 VTs Phase-To-Earth

VT'S AND CT'S UNITS

MTV - VT UNIT

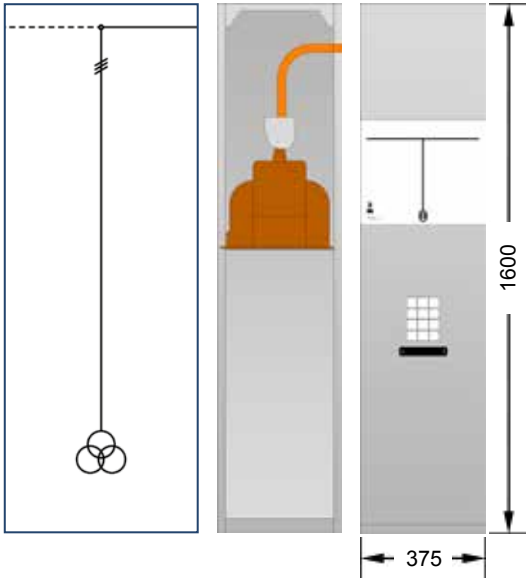

2 VTs Phase-To-Phase only Up to 12kV

MTVS - VT AND SURGE ARRESTERS UNIT

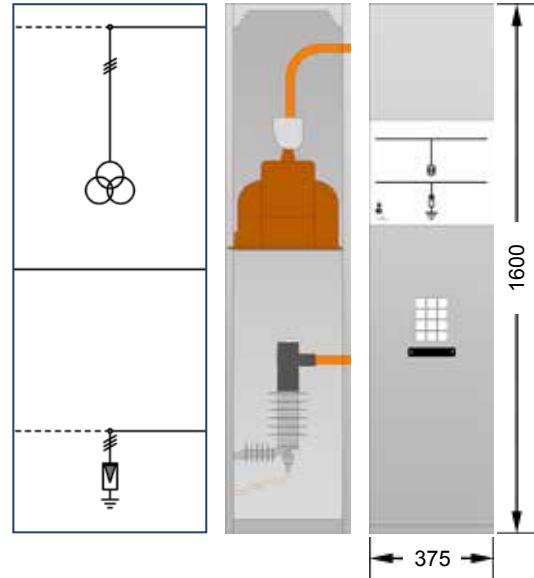

2 VTs Phase-To-Phase only Up to 12kV

FMM - CT UNIT WITH FUSES

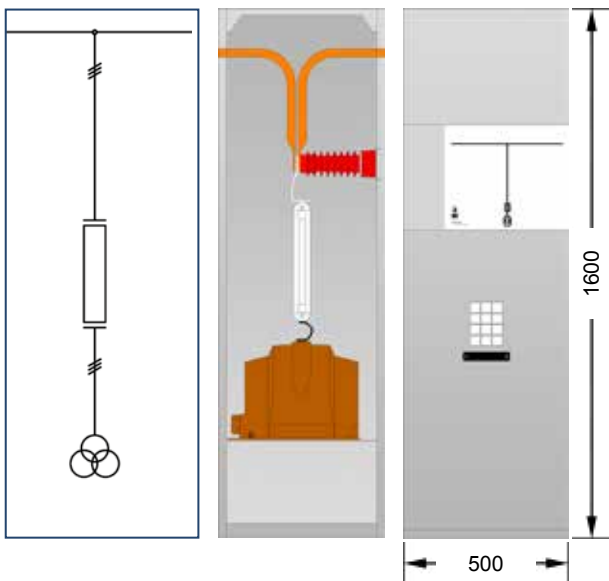

MTA - CT UNIT

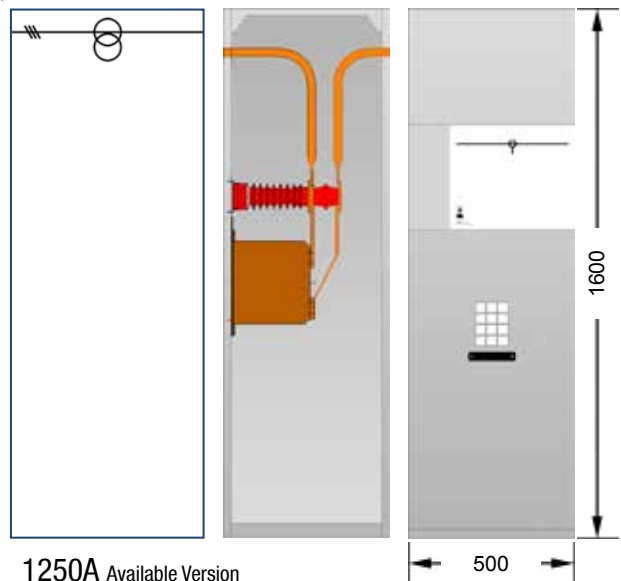

1250A Available Version

CABLES AND BUSBARS EARTHING UNITS

ESM - BUSBAR EARTHING UNIT

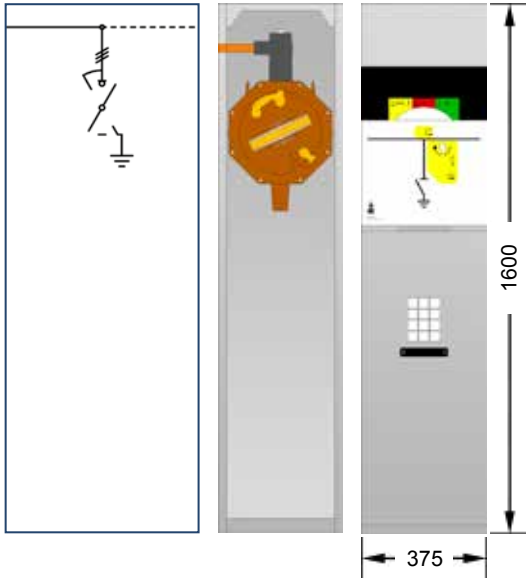

CME - CABLE RISER UNIT WITH EARTHING SWITCH

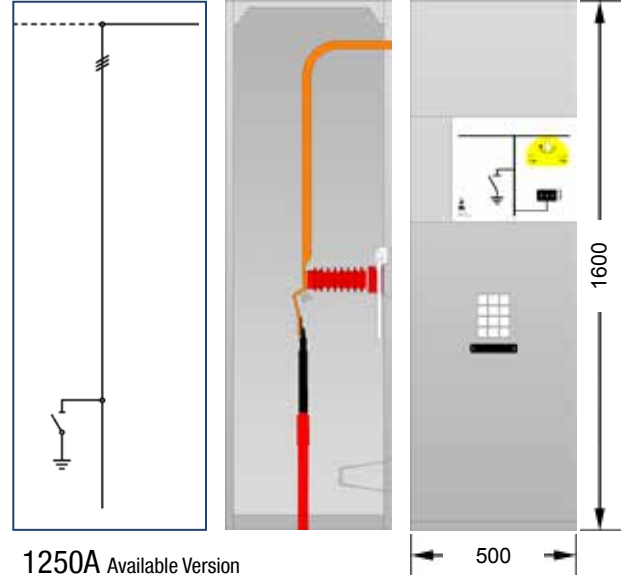

METERING UNITS WITH SWITCH DISCONNECTOR

SMM - METERING UNIT WITH SWITCH DISCONNECTOR

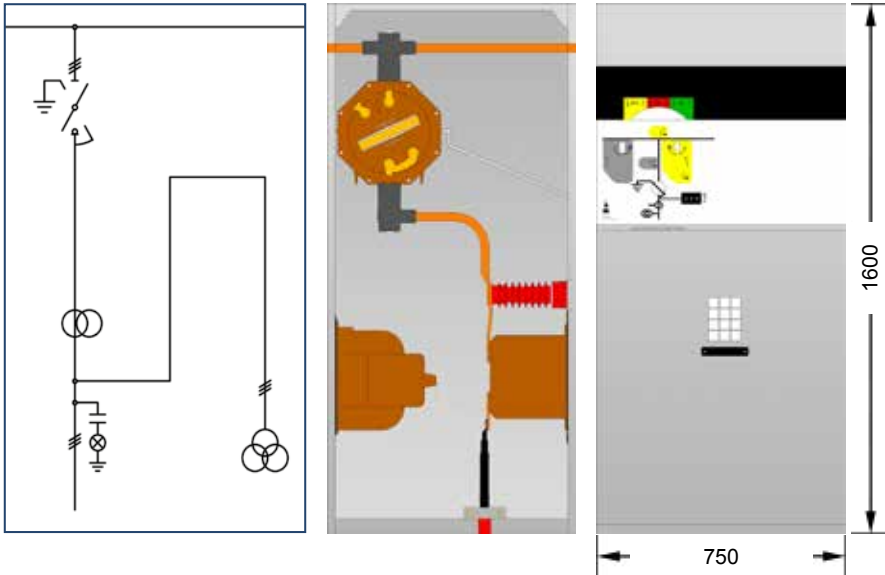

Max 2 VTs Phase-To-Phase + 3 VTs Phase-To-Earth

SMMR - METERING UNIT WITH SWITCH DISCONNECTOR AND BUSBAR RISER

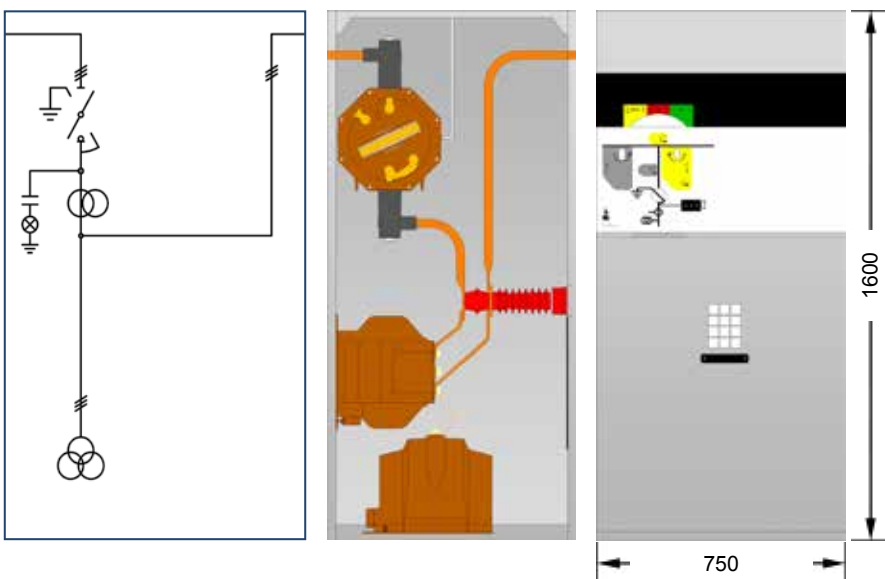

Max 2 VTs Phase-To-Phase + 3 VTs Phase-To-Earth

METERING UNITS

MBMP - METERING UNIT

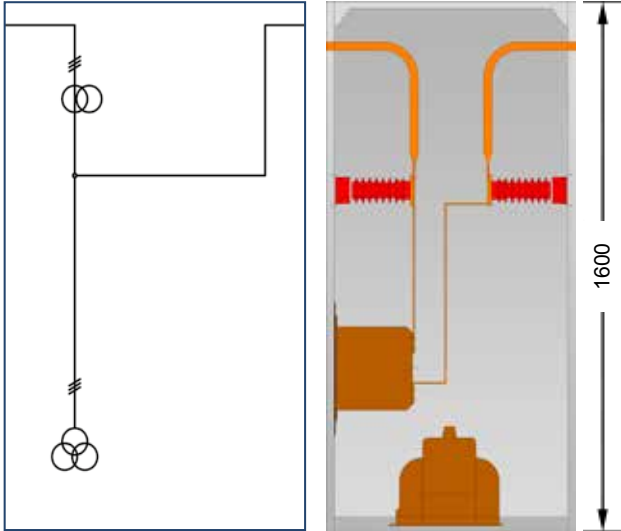

1250A Available Version

To install fuses in combination with VTs contact SEL.

MBMR - METERING UNIT WITH RIGHT OR LEFT OUTGOING LINE

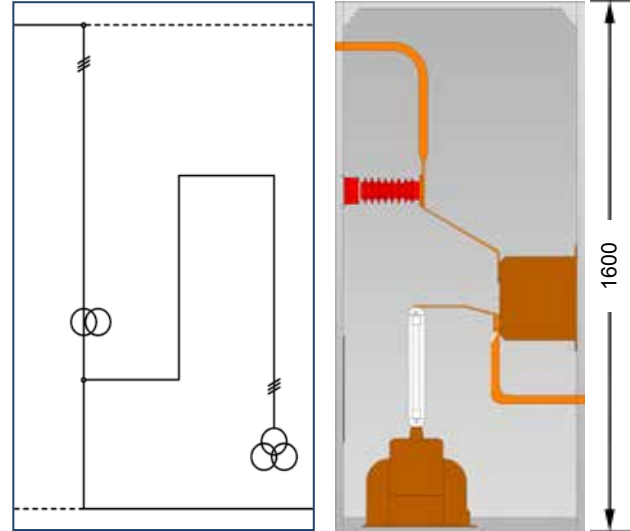

1250A Available Version

To install fuses in combination with VTs contact SEL.

MBER - METERING UNIT WITH RIGHT OR LEFT OUTGOING LINE AND EARTHING SWITCH

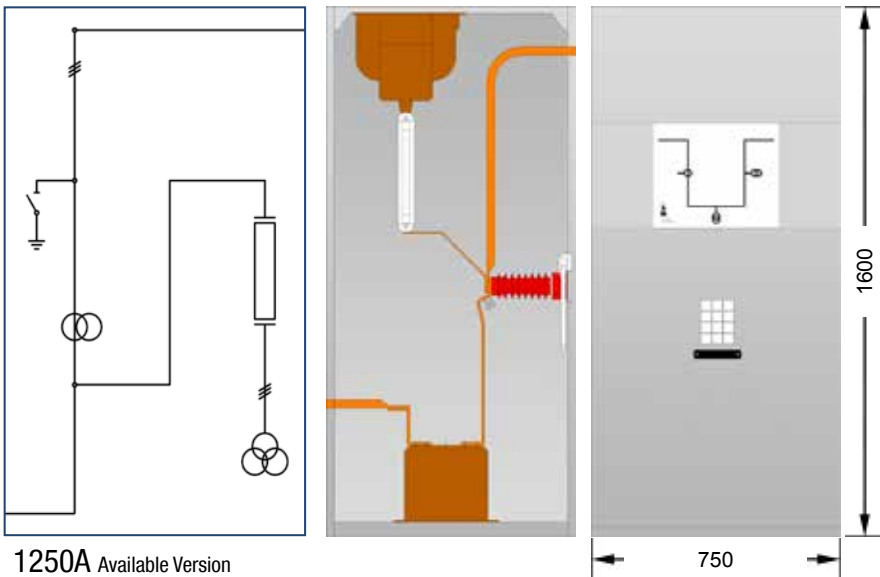

1250A Available Version

To install fuses in combination with VTs contact SEL.

CONFIGURATION OF MEASUREMENT TRANSFORMER		
CTs	VTs	
	PHASE-TO-EARTH	PHASE-TO-PHASE
-	9	-
-	-	6
9	-	-
6	-	2
3	-	4
-	6	2
-	3	4
3	6	-
6	3	-
3	3	3

MBMC - METERING UNIT WITH LOWER OUTGOING CABLES

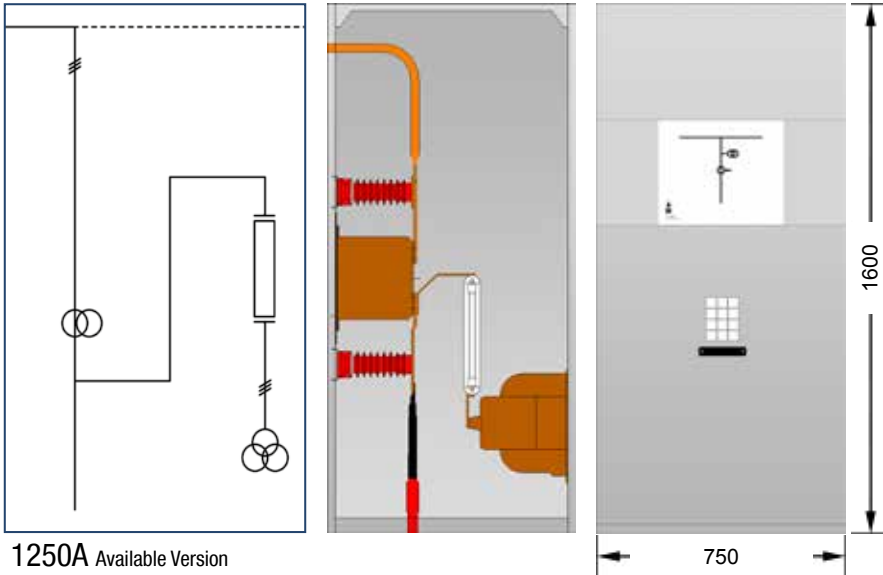

1250A Available Version

To install fuses in combination with VTs contact SEL.

MCMP - METERING UNIT WITH LOWER INCOMING/OUTGOING CABLES

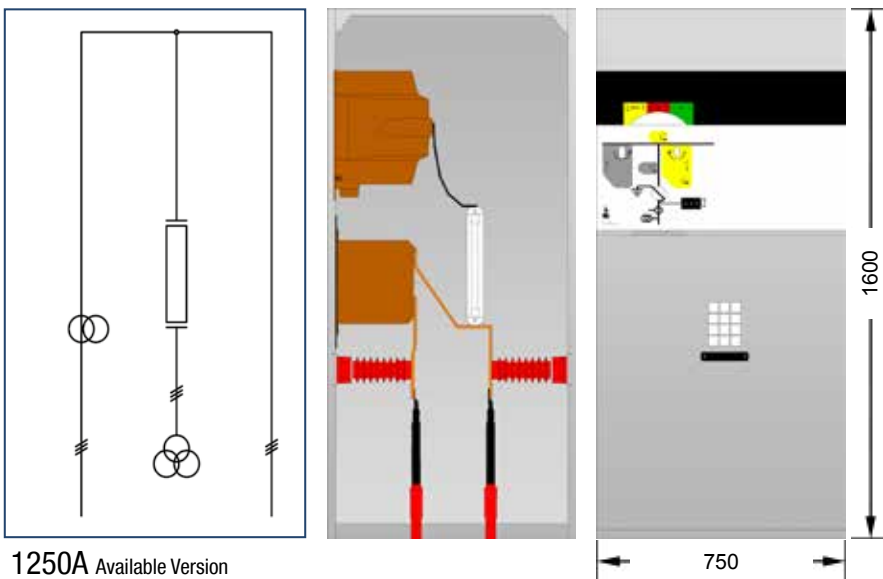

1250A Available Version

To install fuses in combination with VTs contact SEL.

CONFIGURATION OF MEASUREMENT TRANSFORMER		
CTs	VTs	
	PHASE-TO-EARTH	PHASE-TO-PHASE
-	9	-
-	-	6
9	-	-
6	-	2
3	-	4
-	6	2
-	3	4
3	6	-
6	3	-
3	3	3



Bases and Busbars	42
Keylocks and Padlocks Holder	42
Protection Relay	44
Automatic Change Over System (ACO)	45
Fuses	46
Surge Arrester and Measuring Instruments	47
Cables Connection - Connection Height	48
Motorizations - Voltage Indicator - HVSensor	50
Other Accessories	51
Civil Works - Distance from the wall	53
Basement hole for cables incoming/outgoing	54
Hole positioning for floor mounting	55
Standard Units Dimensional Data	56
Internal Arc Proof Upward Exhaust units Dimensional Data	58
Internal Arc Proof Downward Exhaust units Dimensional Data	60
Operation Sequences	62

BASES AND BUSBARS



BASE

As an option all the units and standard configurations can be equipped with a 350mm high bases. The base is only applicable for standard series "IAC: A-FL 12,5kA 1s".

The use of base simplifies cable connection, helps to keep the correct bending radius of the cables and reduces the trench depth in civil engineering works.

BASE OVERALL DIMENSIONS			
WIDTH	HEIGHT	DEPTH	
375	350	840	
500	350	840	
750	350	840	

BUSBARS





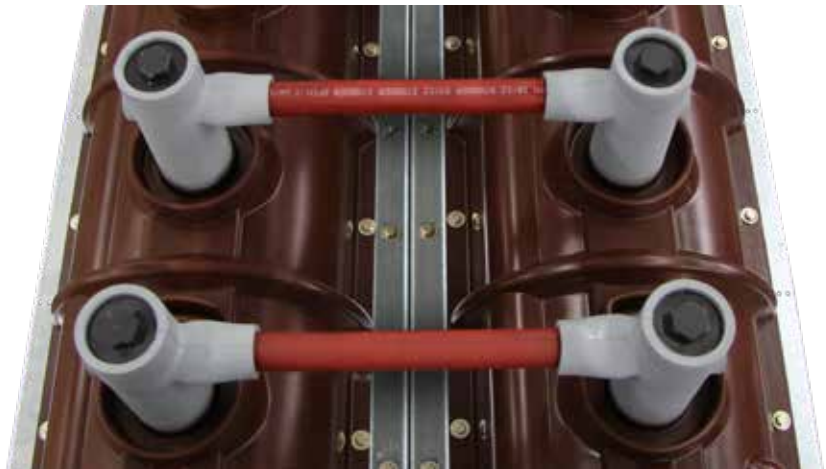

Busbars coupling kit on TPS switch. 24kV busbars are completely insulated.

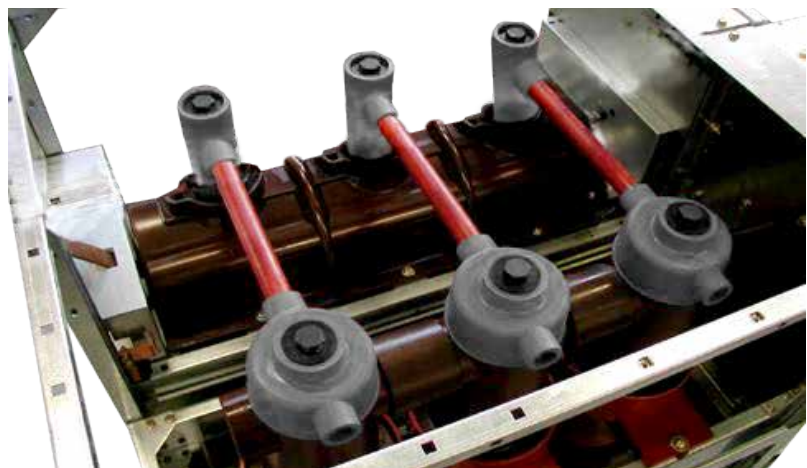

Busbars coupling kit on TPS switch. 24kV busbars are completely insulated.

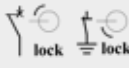

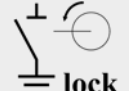
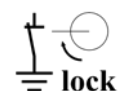
KEYLOCKS AND PADLOCK HOLDER

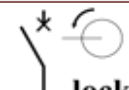
	SYMBOL	DESCRIPTION	Op. MECHANISM				
			NL	TCB	LT	3D	E
A		KEYLOCK, FREE "A" KEY WITH EARTHING SWITCH CLOSED AND CIRCUIT BREAKER CLOSED AND THE "B" KEY IS INSERTED, (ONLY FOR ILCBV)		■			
B+E		(THE "B" KEY IS RINGED WITH THE "E" KEY) KEYLOCK, WHEN THE SWITCH IS IN EARTH CLOSED POSITION AND THE CIRCUIT BREAKER IS CLOSED FREE THE "A" KEY (ONLY ILCBV)		■	■		
C		KEYLOCK WITH SWITCH OPENED: WHEN THE SWITCH IS OPENED, TURN THE KEY ANTICLOCKWISE AND REMOVE IT IN ORDER TO PREVENT THE CLOSING OF CIRCUIT	■		■	■	
D		KEYLOCK WITH EARTHING SWITCH OPENED: WHEN THE EARTHING SWITCH IS OPENED, TURN THE KEY ANTICLOCKWISE AND REMOVE IT IN ORDER TO PREVENT THE EARTHING.	■		■	■	■
E		KEYLOCK WITH EARTHING SWITCH CLOSED: WHEN THE EARTHING SWITCH IS CLOSED, TURN THE KEY CLOCKWISE AND REMOVE IT IN ORDER TO PREVENT THE OPENING OF THE EARTHING SWITCH.	■		■	■	■
F		KEYLOCK WITH SWITCH CLOSED: WHEN THE SWITCH IS CLOSED, TURN THE KEY ANTICLOCKWISE AND REMOVE IT IN ORDER TO PREVENT THE CLOSING OF CIRCUIT	■				
I		KEYLOCK WITH CIRCUIT BREAKER OPENED: WHEN THE CIRCUIT BREAKER IS OPENED, TURN THE KEY CLOCKWISE AND REMOVE IT IN ORDER TO PREVENT THE CLOSING OF CIRCUIT BREAKER.		■			
G		PADLOCK HOLDER ON DISCONNECTOR/ SWITCH-DISCONNECTOR	■		■	■	
H		PADLOCK HOLDER ON EARTHING DISCONNECTOR/ EARTHING SWITCH	■		■	■	■



LT Operating mechanism

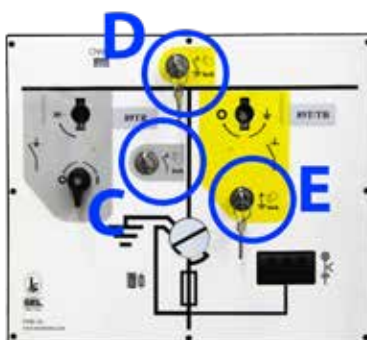

3D Operating mechanism



For ILCBV, TCB CBunit operating mechanism

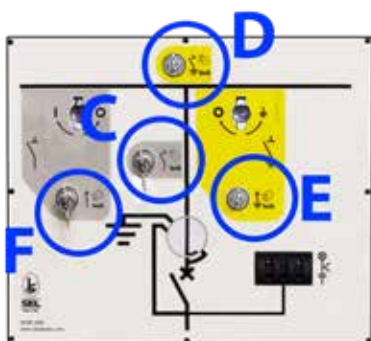

NL Operating mechanism

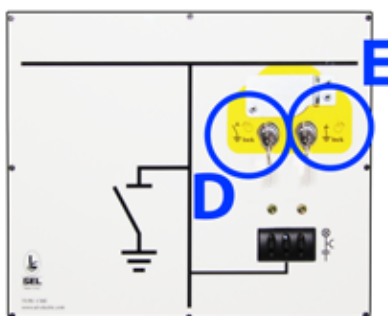

E Operating mechanism



TCB CB unit operating mechanism, Not for ILCBV

PROTECTION RELAY

PROTECTION RELAY

TPS range can be provided with self-powered protection relays with ring core CTs on cables or protection relays with power supply. All the relays used are well-known brands with high level of safety and reliability.

In some cases the protection relay is installed directly on board of the circuit breaker, in other cases when the protection relay dimensions are bigger or when the wiring diagram is more complex, the protection relay is installed in the LV compartment located on the top or in front of the switchgear.

The LV compartment can be installed on the roof or on the front of the unit. The frontal LV compartment can be used in case of very simple and small LV accessories. The LV compartment (height 450mm) is necessary for larger and more complex LV accessories and if the unit is provided with Automatic Change Over system.

WIDTH	HEIGHT	DEPTH
375	450	300
375	250(*)	240
500	450	300
750	450	300

(*) ICBV and ILCBV can be provided with 250mm high LV compartment in withdrawable version.

Protection Relay installed in LV Compartment

Protection Relay installed in LV Compartment (ICBV)

Protection Relay installed on frontal panel.

Protection Relay installed in LV Block Compartment



Fuses

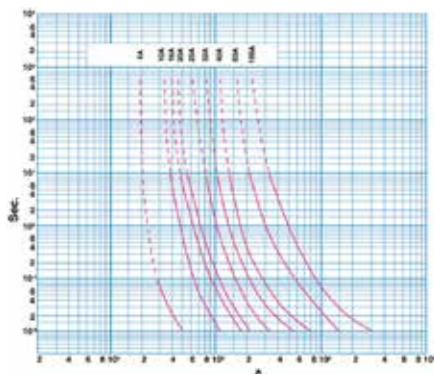

Standard fuses

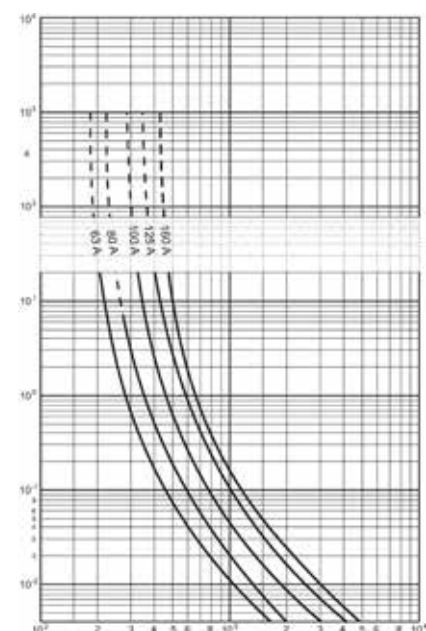

Special fuses up to 12kV

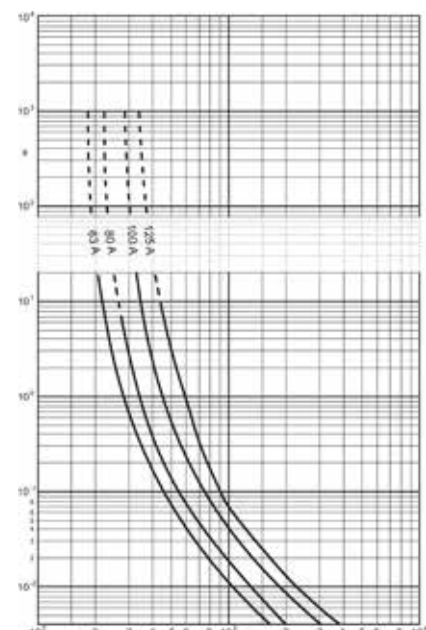

Special fuses up to 24kV

Fuse selection

Some important transformer and fuse features have to be known to select the right fuse for power transformer protection:

Transformer:

Rated power	P_n [kVA]
Short circuit voltage	U_{cc} [%]
Service rated voltage	U_n [kV]
Rated current	I_n [A]
Inrush maximum current	I_i [A] (usually $12 \times I_n$)
Overload current	I_s [A] (usually $1,5 \times I_n$)
Short circuit current	I_{cct} [A]
Maximum time withstand short circuit	t_m [s] (usually 2s for transformer up to 630kVA, 3s for bigger transformer)

Fuse

Rated insulation voltage	V_i [kV]
Rated current	I_n [A]
Maximum breaking current	I_b [kA]
Minimum breaking current	I_3 [A]
Power losses at I_n	P_w [W]

Time/current characteristic to get follow values:

Pre-arcing current at 0,1s	$I_f(t=0,1s)$ [A]
Pre-arcing current at t_m	$I_f(t=t_m)$ [A]
Pre-arcing current at 0,05s	$I_f(t=0,05s)$ [A]

Verify following conditions:

- The rated insulation voltage of the fuse has to be higher than the service rated voltage of the transformer $V_i > U_n$
- The fuse has to be able to break the maximum short circuit current of the plant $I_b > I_{cct}$ (in case of fault before the transformer)
- The fuse melts in case of fault on LV wiring of the transformer $I_3 < I_{cct}$
- The fuse protects the transformer in case of short circuit $I_f(t_m) < I_{cct}$
- The fuse does not melt at the transformer withstand overload $I_n > I_s$
- The fuse does not melt at the transformer inrush current $I_f(0,1s) > I_i$
- The fuse power dissipation does not compromise the temperature inside the switchboard $P_w < 150W$
- The transfer current has to be lower than the maximum admissible value for the switchboard $I_f(0,05s) < I_{transfer}$

Standard

Striker pin fuses (1 ± 0.25 Joule) in accordance with:

- IEC 60 282-1/VDE 0670-4
- IEC 60 787/VDE 0670-402
- DIN 43 625

Selection table helps to select the fuses for generic MV/LV power transformers; it is valid for ambient air temperature up to 40°C and it has to be verified with all above parameters.

FUSES SELECTION TABLE															
V_s	V_i	P_n [kVA]													
[kV]	[kV]	100	125	160	200	250	315	400	500	630	800	1000	1250	1600	2000
6	12	20	25	31,5	40	50	63	80	100	125	160	-	-	-	-
6,6	12	16	20	25	31,5	40	50	63	80	100	125	160	-	-	-
10	12	16	16	20	25	31,5	40	50	63	80	100	125	160	-	-
11	12	16	16	16	20	25	31,5	40	50	63	80	100	125	160	-
15	24	10	10	16	16	20	25	31,5	40	50	63	80	100	125	-
20	24	6	10	10	16	16	20	25	31,5	40	50	63	80	100	125
23	24	6	6	10	10	16	16	20	25	31,5	40	50	63	80	100
33	36	4	6	6	10	10	10	16	20	25	31,5	40	40	50	63
36	36	4	6	6	10	10	10	16	16	20	25	31,5	40	50	63

Surge Arrester and Measuring Instruments

SURGE ARRESTERS



Insulating base



Surge Arrester



Disconnecter Device



Impulse Counter

Insulating base has to be installed in case the automatic disconnector is used to prevent potential earth faults.

Impulse meter counts only the impulses or it can also measure the leakage current. Both kind of solutions can be supplied with auxiliary contact 0,5 A / 250 V for remote control on request. Disconnecter Device disconnects overloaded arresters from power supply in case of internal fault or informs about the faulty surge arrester.

ELECTRICAL CHARACTERISTICS

Discharge rated current	10 kA
Rated voltage	3 ÷ 33 kV
Discharge max. current	100 kA
Discharge current for 2 sec	250 A
Ambient temperature	-40 ÷ +55 °C
Altitude of installation	Up to 1000m

MEASURING INSTRUMENTS

Digital Ammeter
Current switch
Voltmeter (range from 0-90°, cl. 1,5)
Digital Voltmeter
Voltmeter switch
3 Phase measure transducer
Monophase measure transducer
3 Phase active energy counter
Protected terminal for measure control
3 Phase reactive energy counter
Multifunctional meter [V-A-cosØ-W-VAR-Wh-VARh-Hz]
Multifunctional meter [V-A-cosØ-W-VAR-Wh-VARh-Hz] with RS485 output
3 Phase counter Bidirectional active and reactive energy, in according with AEEG
Sealing Kit for measuring unit.
Analogic ammeter (range from 0- 90°, cl. 1,5)

CABLES CONNECTIONS

UPPER INPUT/OUTPUT CABLE BOX

Not available for internal arc proof series.

Upper input cable box can be used in the following situations:

- Fig.1 Switch Disconnecter with only cable.
- Fig.2 Switch Disconnecter with cable + right busbar.
- Fig.3 Switch Disconnecter with cable + double busbar.
- Fig.4 Switch Disconnecter with cable + left busbar.
- Fig.5 Circuit Breaker with only cable.

LATERAL INPUT/OUTPUT CABLES

Fig.6/7 Lateral input cables from CM unit.

Fig.8 Lateral Outgoing cable system from ICBV/ILCBV to transformer

LOWER INPUT/OUTPUT CABLES

Fig.9 Cables connection on the switch terminals in FS unit (standard)

Fig.10 Cables connection on the circuit breaker connector (standard).

Fig.11 Single cable connection on the measuring unit (standard).

Fig.12 Double cables connection on the measuring unit (Only MCMP unit).

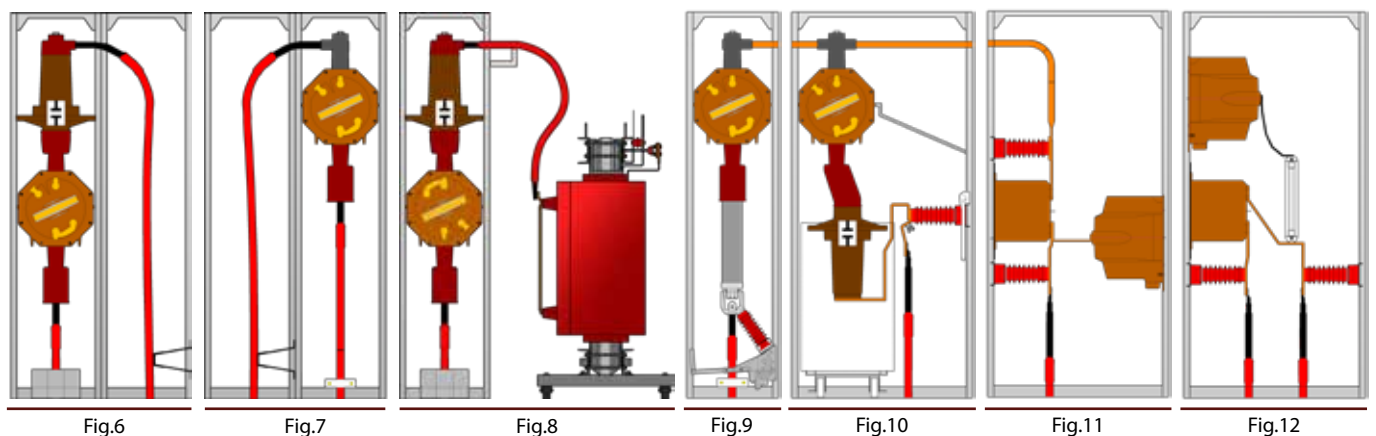
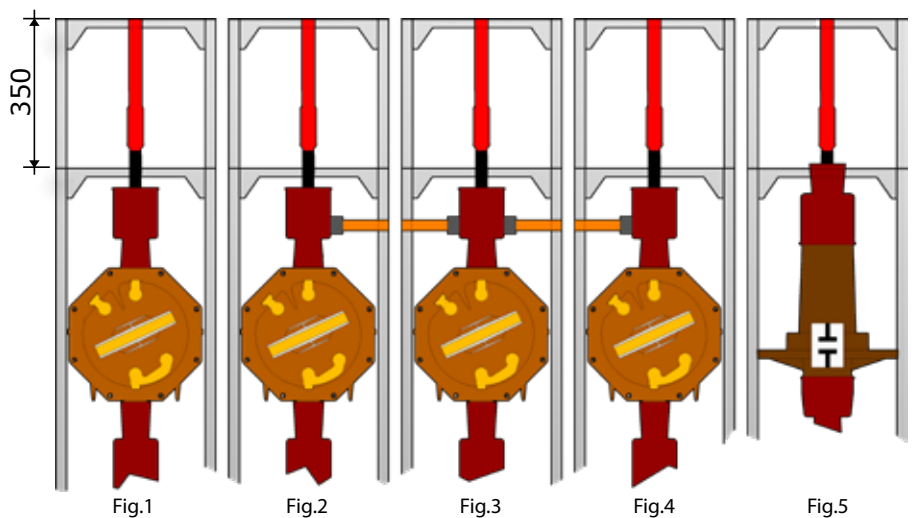

Connection Height Cable terminal connection point

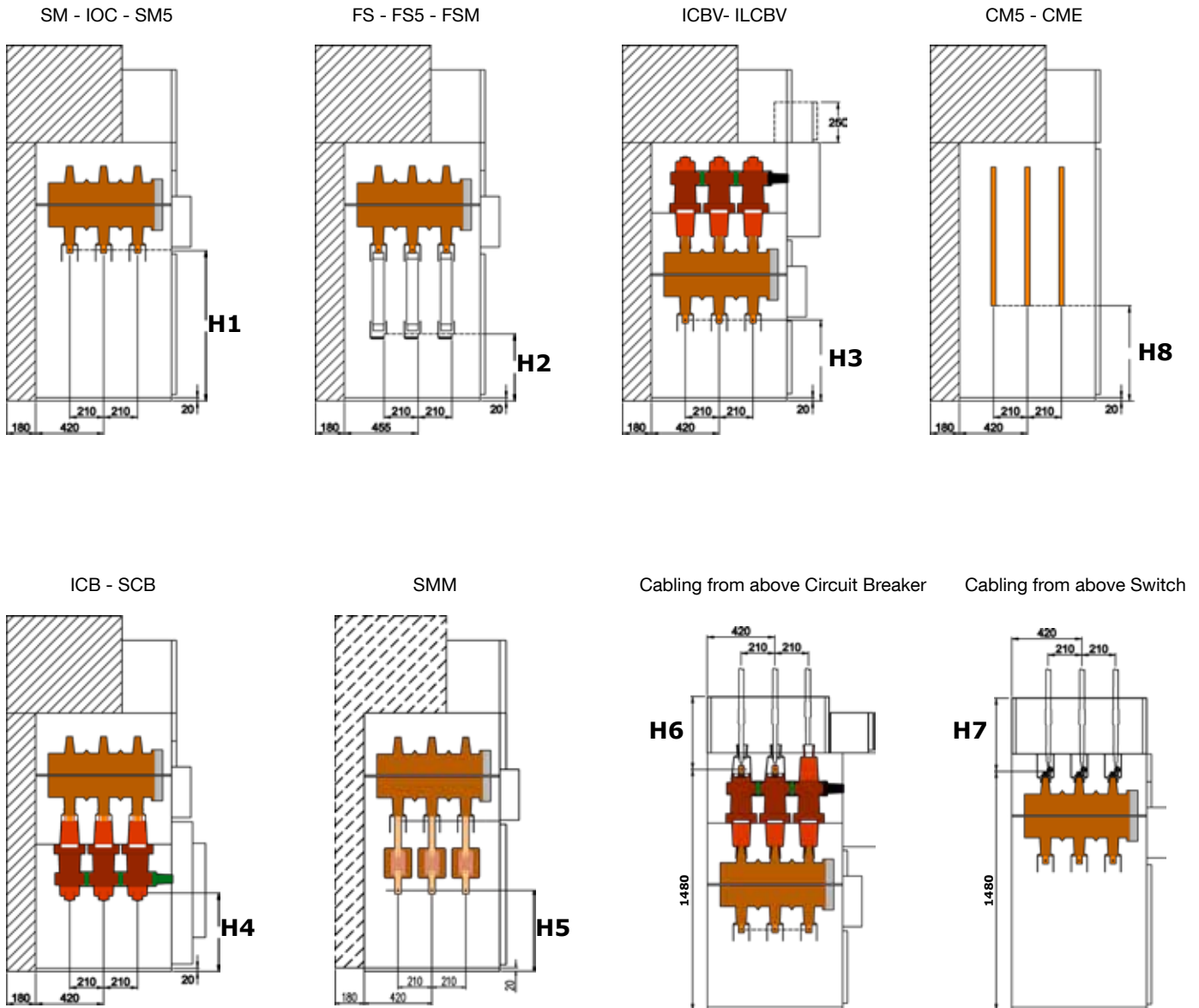

HEIGHT FROM THE FLOOR		NOTES
H1	940	MAXIMUM 2 CABLES FOR PHASE 240 mm ²
H2	380	MAXIMUM 2 CABLES FOR PHASE 70 mm ²
H3	500	MAXIMUM 2 CABLES FOR PHASE 240 mm ²
H4	400	MAXIMUM 2 CABLES FOR PHASE 240 mm ²
H5	500	MAXIMUM 2 CABLES FOR PHASE 240 mm ²
H6	470	MAXIMUM 1 CABLE FOR PHASE 120 mm ²
H7	470	MAXIMUM 2 CABLES FOR PHASE 120 mm ²
H8	640	MAXIMUM 2 CABLES FOR PHASE 240 mm ²

MOTORIZATIONS - VOLTAGE INDICATOR - HVSENSOR



LT Motorization Upgrade

TCB Motorization Upgrade

MOTORIZATION

All our operating mechanisms have the possibility to equip the motorizations upgrade, except the 3D operating mechanism that is built with or without the motorization.



VOLTAGE INDICATOR

Voltage presence indicating system. Integrated 3-phase test point for phase comparison test.

The Voltage Presence Indicating System (VPIS) SEL

Compliant with the standard IEC 62271-206, allows to display the voltage presence of the three phases by means an LCD, and to do a phase-concordance test between two lines, on all the SEL S.p.A. switchboards indoor and outdoor.

The voltage presence is indicated by the appearance on the display of the symbol 

According to the standard IEC 62271-206, the indication will appear for voltages (line-to-earth) greater than 45% of the minimum rated voltage U_{nmin} , and will completely disappear for voltages (line-to-earth) less than 10% of the maximum rated voltage U_{nmax} . By U_n we mean the line voltage (phase-to-phase) applied to the switchboard.

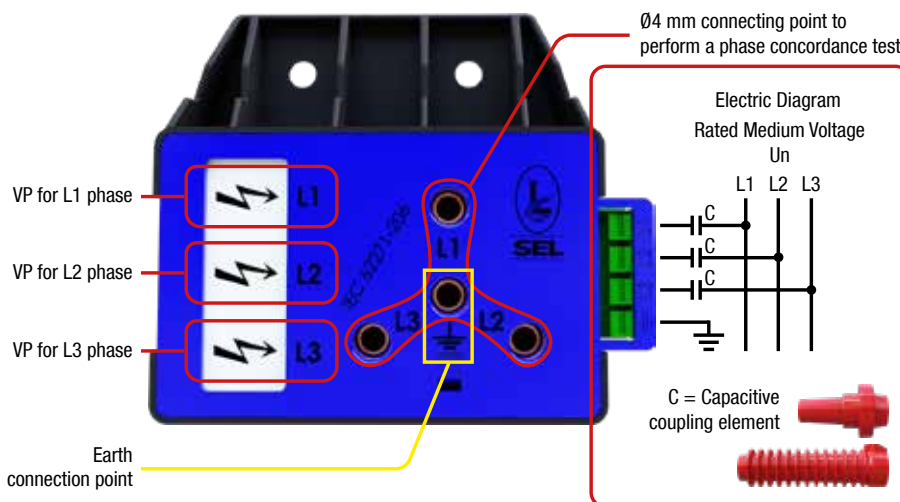

HVSENSOR VOLTAGE DETECTOR

Voltage detector with relay output. Use in combination with Voltage Indicator.



VOLTAGE DETECTING SYSTEM ACCORDING TO IEC 61243-5

Integrated voltage indicator VOIS+, VOIS R+



PHASE COMPARISON TEST UNIT MAKE

as combined test unit (HR and LRM) for:

- Voltage detection
- Phase comparison
- Interface test
- Integrated self-test
- Indication via LED.

OTHER ACCESSORIES

SWITCH DISCONNECTOR



Shunt opening release (optional)
Shunt closing release (optional)
Only for 3D op. mech.



Auxiliary contacts (optional)
LT max 4 CO Contacts
3D max 5 CO Contacts



Motor gear (optional)

CIRCUIT BREAKER



Shunt opening release (standard)



Shunt closing release (optional)



Undervoltage release (optional)

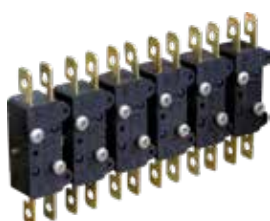

Auxiliary contacts (standard)



Shunt opening release low energy
(standard with self powered protection relay)



Spring charging motor (optional)

OTHER ACCESSORIES

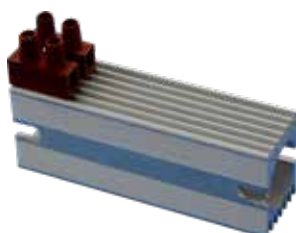

Self-regulating heater 50VA 230V (optional)



Voltage indicator (standard)



HV sensor (optional)

OTHER ACCESSORIES



Manometer (Optional)



Phase concordance unit (optional)

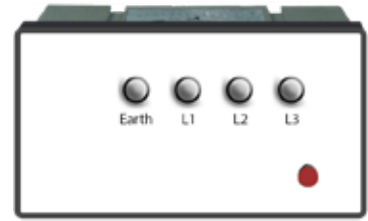

Short circuit indicator and earth fault indicator. Including short-circuit tripping current 300 ÷ 1500A Fiber optic connection.



Earth fault indicator
Including earth fault tripping current : 10 ÷ 60A and auxiliary cable.



Self-supplied remote signalling and Lithium battery.



Cast resin current transformer



Cast resin voltage transformer Phase-phase



Cast resin voltage transformer Phase-earth.



Cable current transformers



Damping resistor



Toroidal transformer.
Important: The copper braid of the cable's shield must be insulated and crossed again inside CT's and toroidal transformer's hole

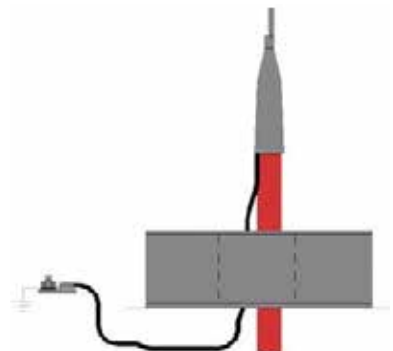

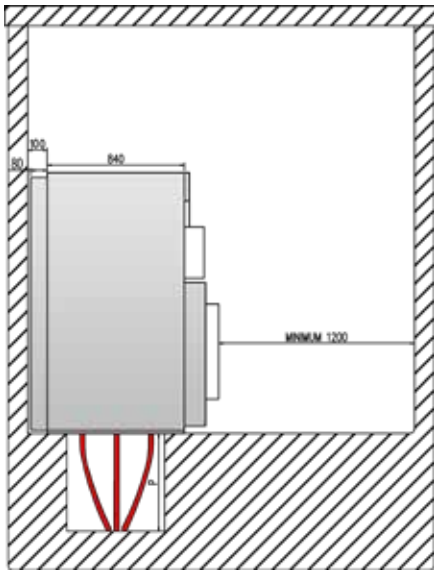

DISTANCE FROM THE WALLS

For some units an additional depth of 80mm is required for the rear panel. Always provide at least 100mm distance from the rear wall. During the installation respect the minimum distances from the wall.

Leave at least 1.2 m operating space in the front of switchgear.

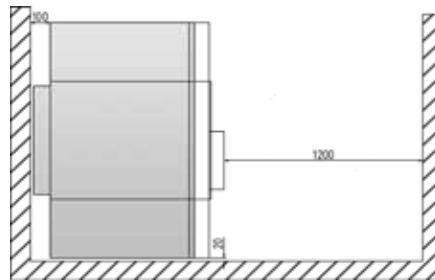

Upper view Standard Version

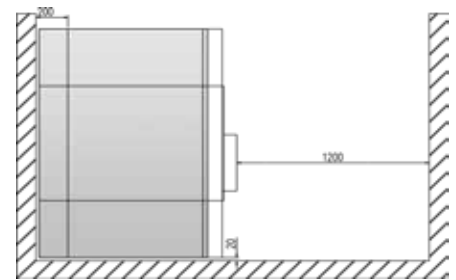

Upper view Internal Arc Proof Version

CABLES TERMINATION

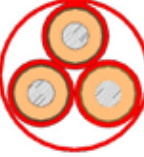
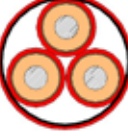
BENDING RADIUS FOR MV CABLES					
CABLE TYPE	CABLE SECTION MM ²	6/10kV INSULATING DEGREE 17 (MM)	8,7/15kV INSULATING DEGREE 24 (MM)	12/20kV INSULATING DEGREE 32 (MM)	15/20kV INSULATING DEGREE 40 (MM)
 Single core	25	290	320	360	—
	35	300	340	360	390
	50	320	350	380	410
	70	340	380	400	440
	95	370	400	430	460
	120	390	420	450	480
	150	400	440	470	500
	185	430	470	490	520
	240	470	500	530	560
	300	500	530	560	600
 Tri-core	25	550	630	720	—
	35	590	670	740	800
	50	620	710	770	830
	70	680	760	830	890
	95	740	820	880	950
	120	780	860	920	990
	150	820	900	970	1030
	185	880	960	1030	1090
	240	960	1040	1100	1160
	300	1040	1110	—	1250
 Tri-core armoured	25	620	710	800	—
	35	670	750	810	880
	50	700	780	850	920
	70	760	840	910	980
	95	810	900	960	1030
	120	860	940	1010	1080
	150	910	990	1060	1120
	185	960	1040	1110	1180
	240	1040	1120	1200	1260
	300	1120	1210	1270	1330

It is important to maintain the bending radius (R) recommended by the MV cable manufacturer. Use of bases makes it possible to respect such a recommendation, reducing the depth of the trench (P) to minimum.

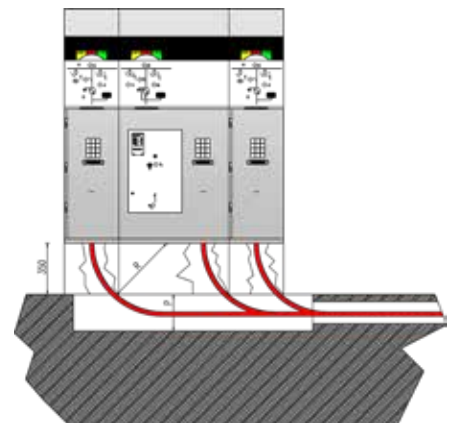
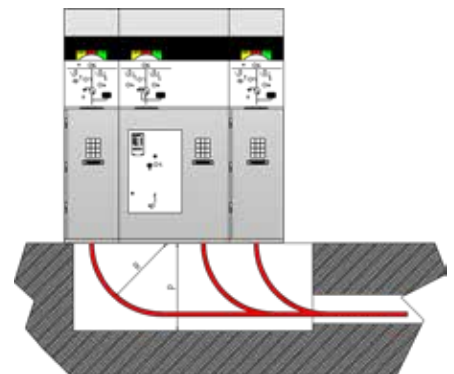

Civil Works



Recommended area for incoming/outgoing cables.

IAC A-FL SERIES (STANDARD)

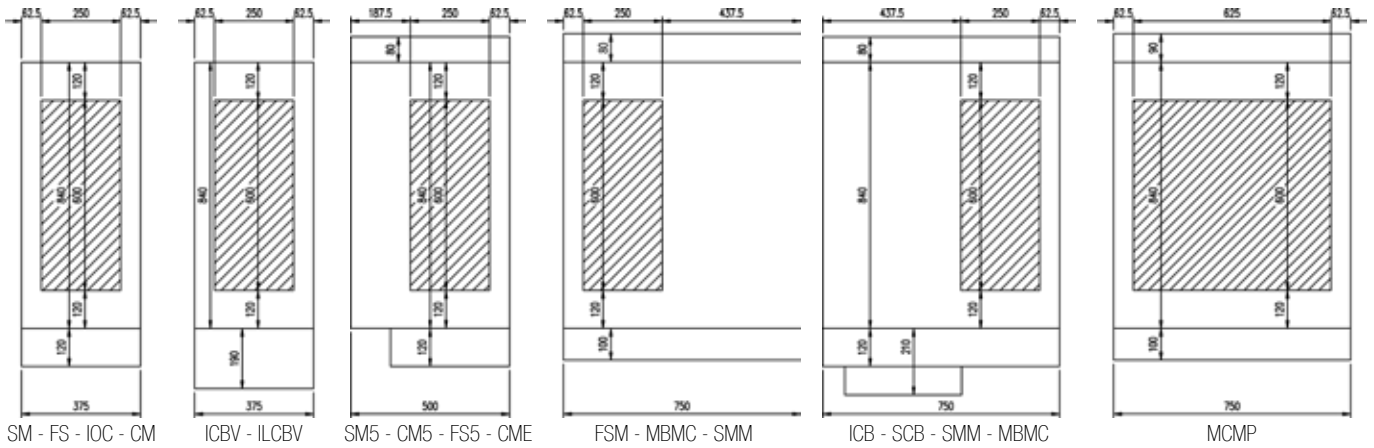

IAC A-FLR SERIES

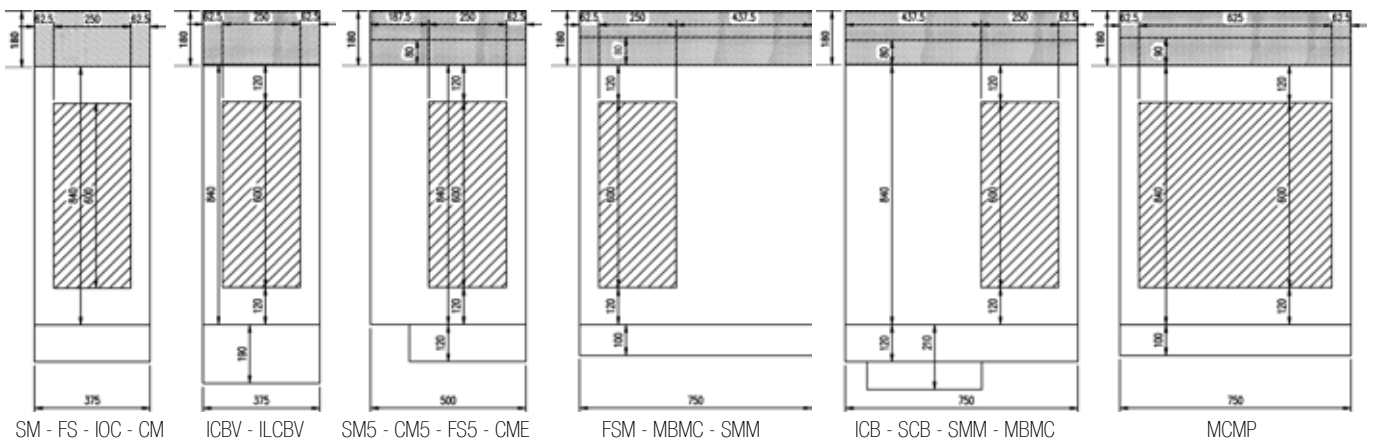

HOLE POSITIONING FOR FLOOR FIXING

It is possible to fix the units to the floor with wedges, using the holes indicated.

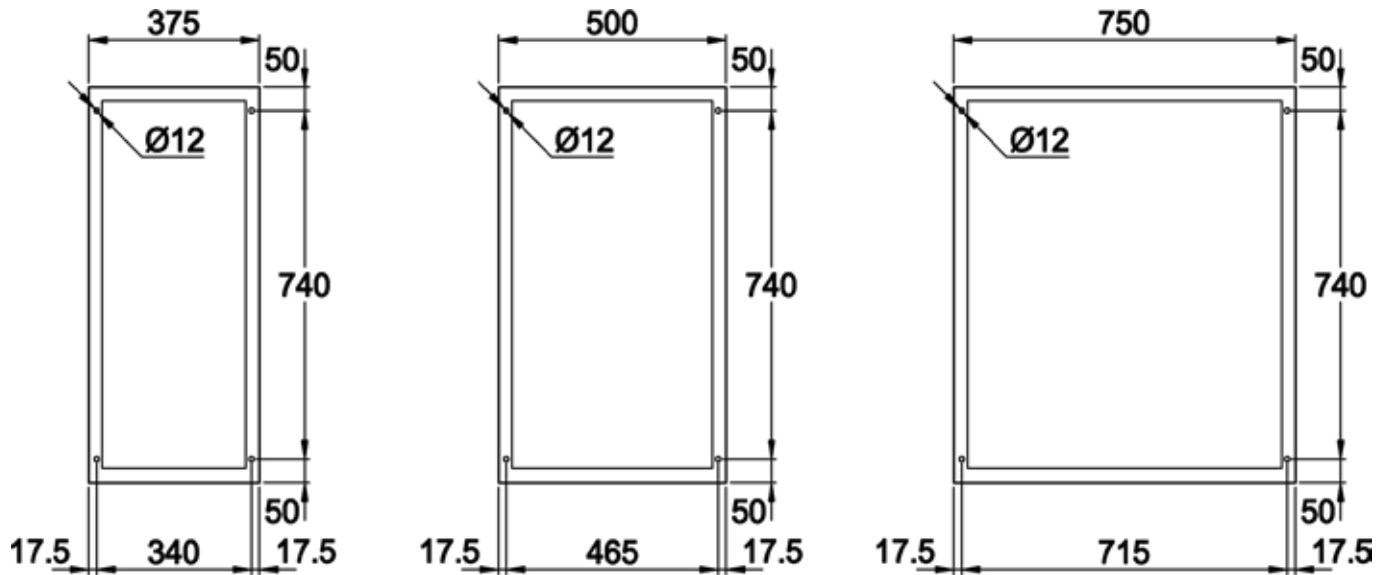

STANDARD UNITS DIMENSIONAL DATA

SM
SMS
FIM
FS
BSM
ESM

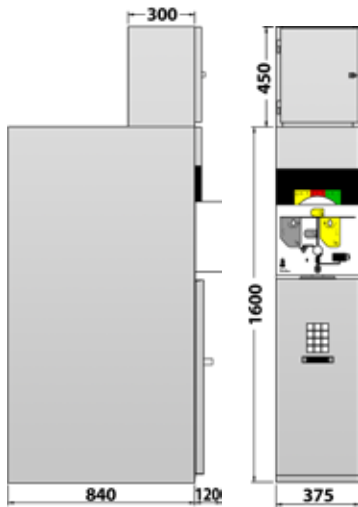

SM5
FS5

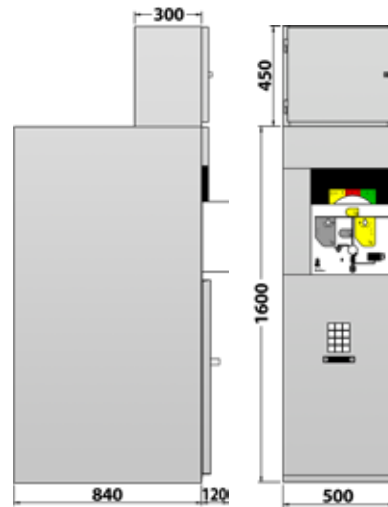

FIM5

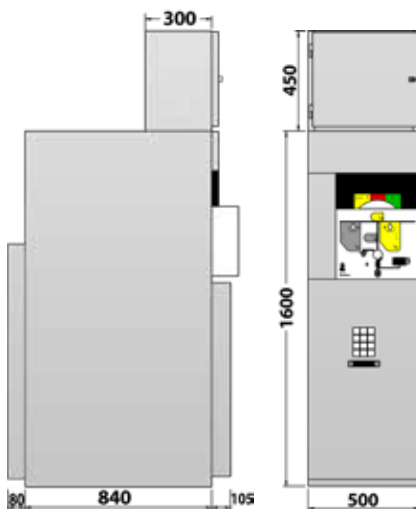

FSM
SMM
SMMR
FIM7

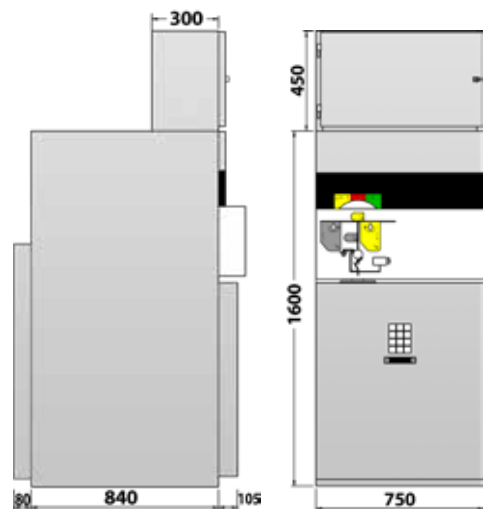

BM
CM
IOC
MTV
MTVS

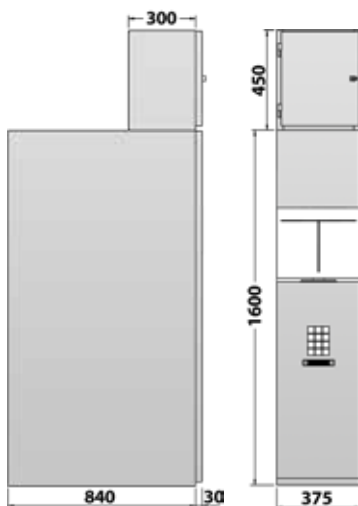

FMM
MTA

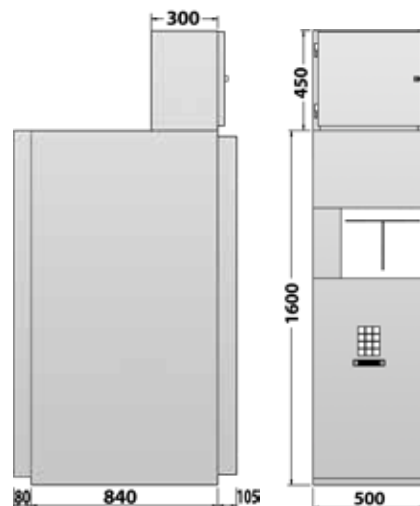

STANDARD UNITS DIMENSIONAL DATA

**MBMP
MBMR
MBMC
MCMP**

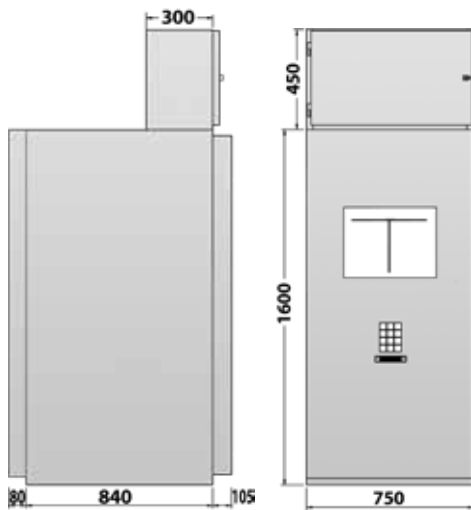

**ICBV
ILCBV**

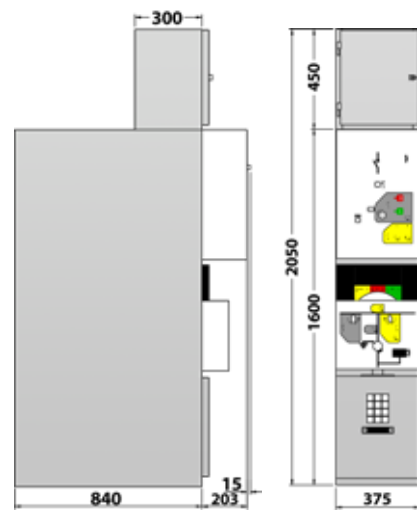

**CM5
CME**

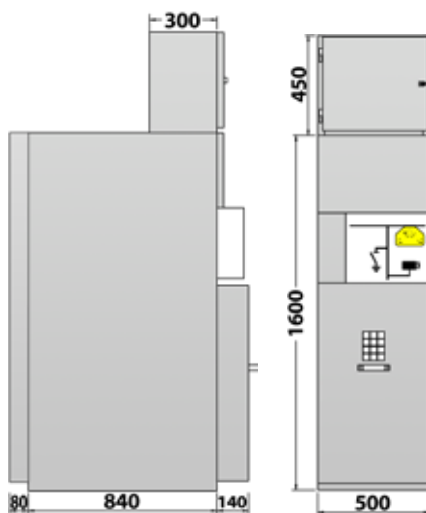

MBER

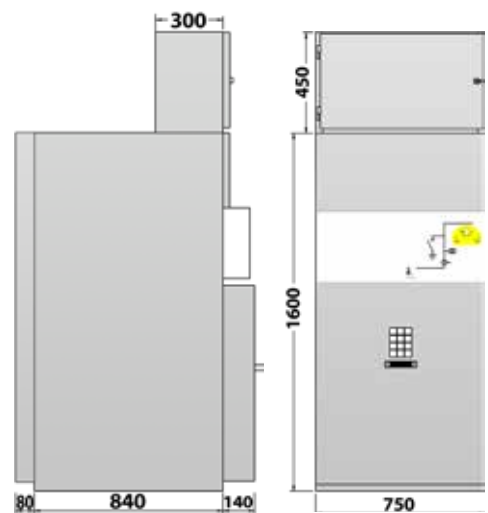

**ICB
ICBR
ICBLT
SCB
SCBR
SCBLT**

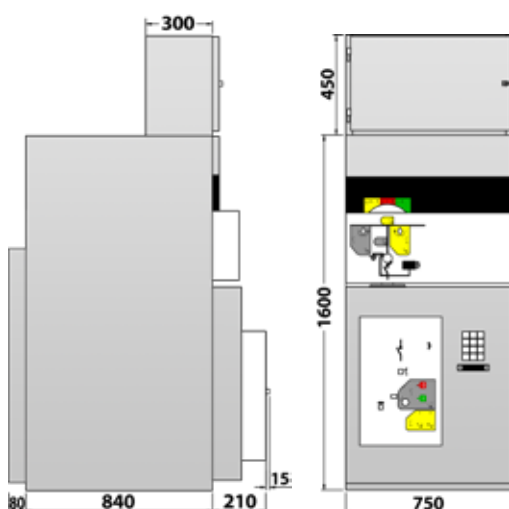

**2ICB
2MCB**

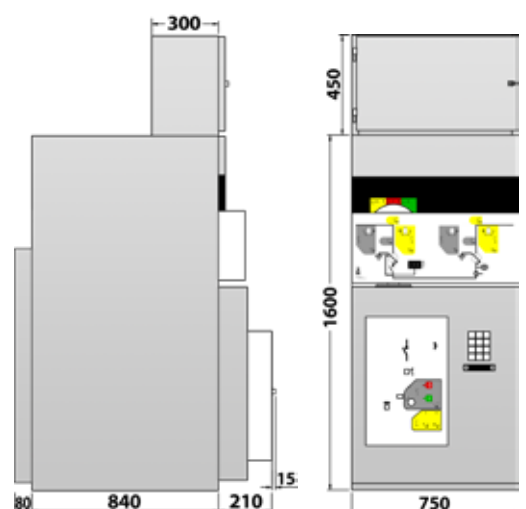

INTERNAL ARC PROOF UPWARD EXHAUST UNITS DIMENSIONAL DATA

UPWARD EXHAUST

SM
SMS
FIM
FS
BSM
ESM

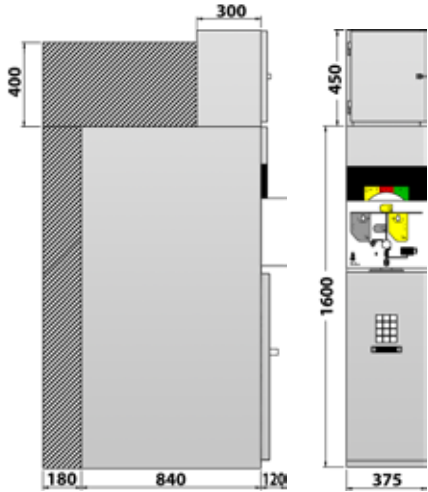

SM5
FS5

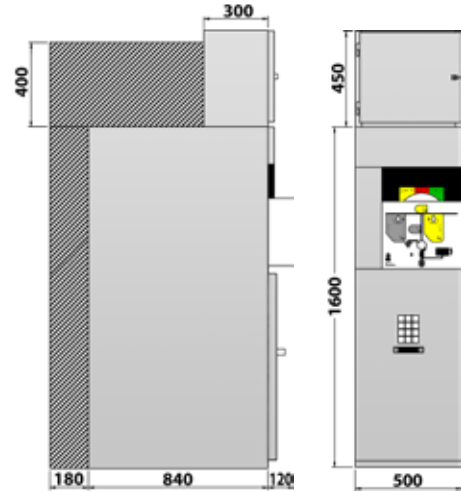

CM5
CME
FIM5

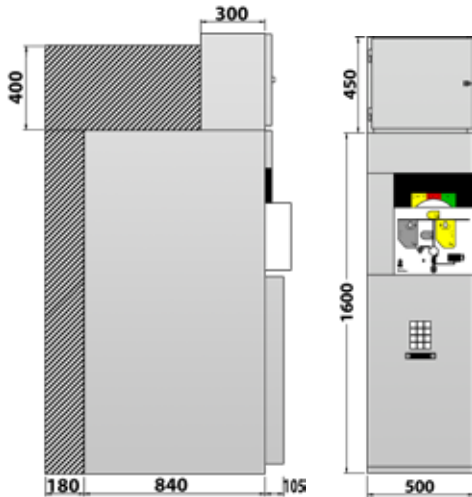

MBER
FSM
SMM
SMMR
FIM7

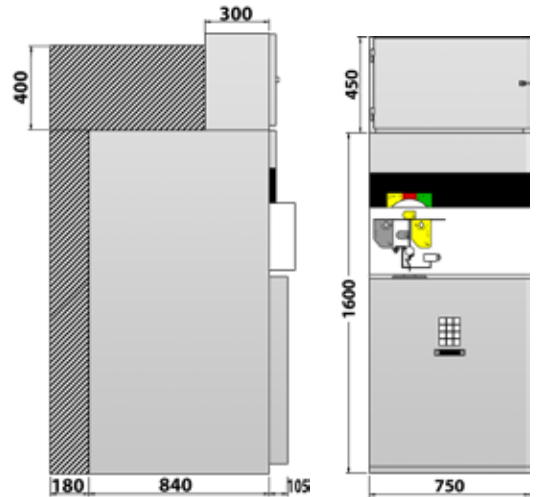

BM
IOC
CM
MTV
MTVS

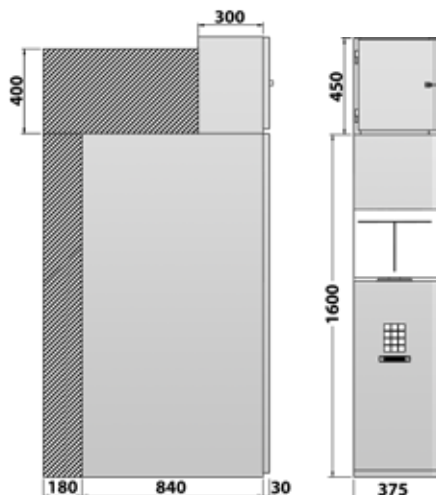

FMM
MTA

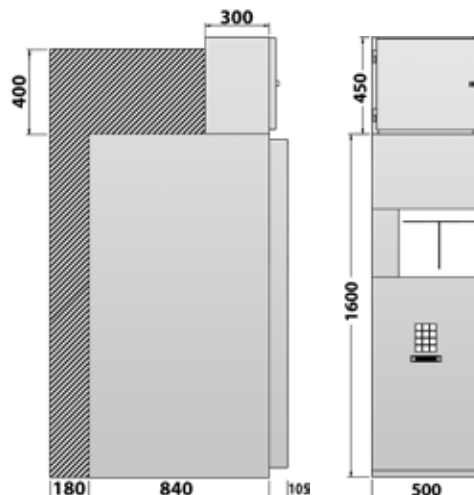

INTERNAL ARC PROOF UPWARD EXHAUST UNITS DIMENSIONAL DATA

**MBMP
MBMR
MBMC
MCMP**

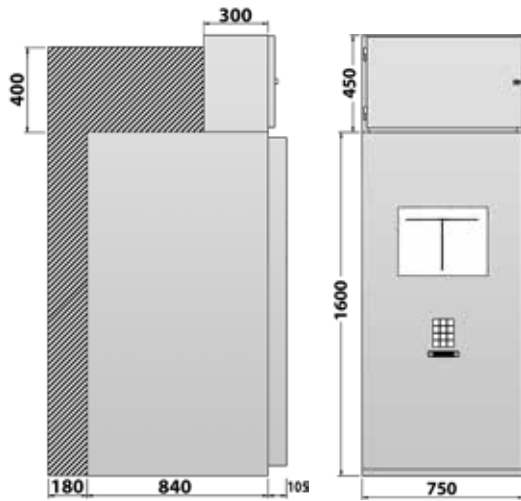

**ICBV
ILCBV**

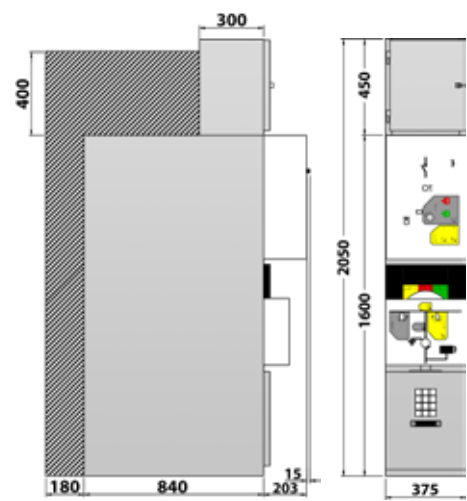

**ICB
ICBR
ICBLT
SCB
SCBR
SCBLT**

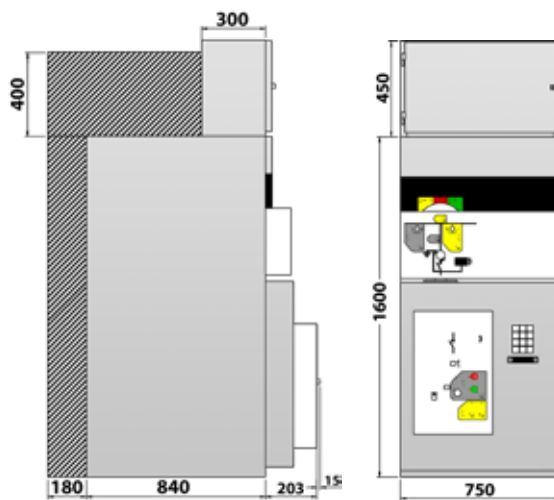

**2ICB
2MCB**

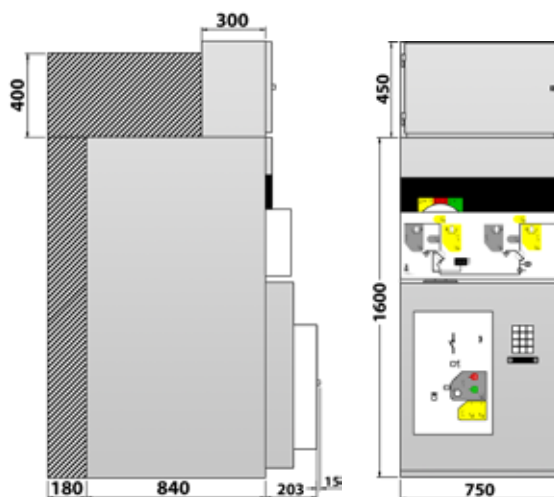

INTERNAL ARC PROOF DOWNWARD EXHAUST UNITS DIMENSIONAL DATA

DOWNWARD EXHAUST

SM
SMS
FIM
FS
BSM
ESM

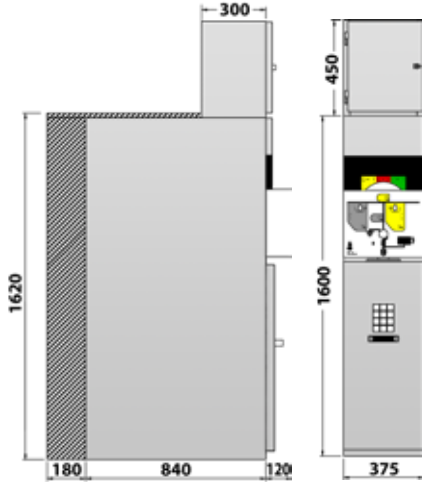

SM5
FS5

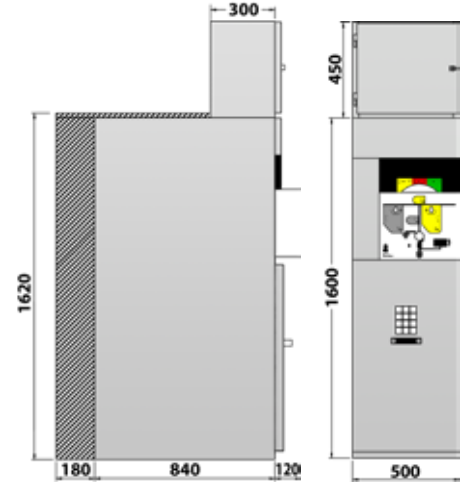

CM5
CME
FIM5

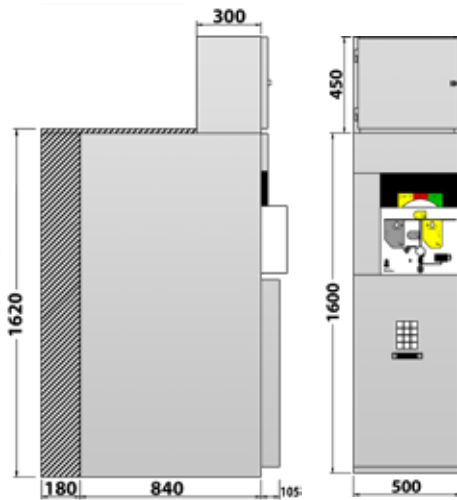

MBER
FSM
SMM
SMMR
FIM7

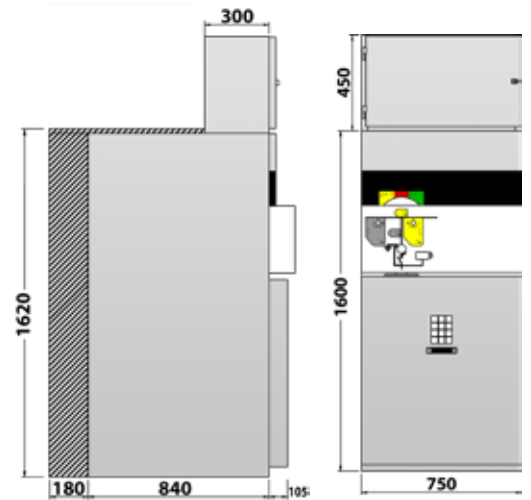

BM
IOC
CM
MTV
MTVS

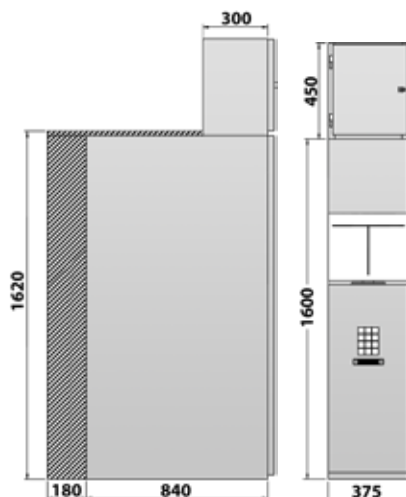

FMM
MTA

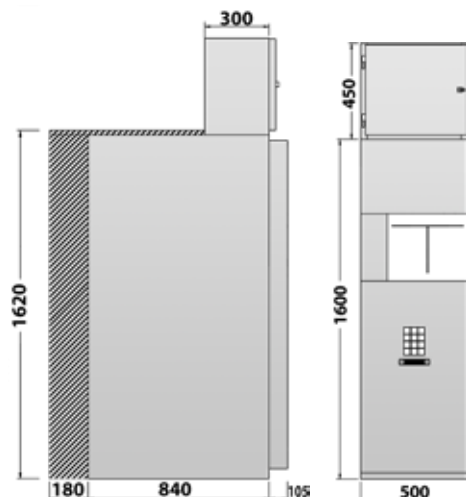

INTERNAL ARC PROOF DOWNWARD EXHAUST UNITS DIMENSIONAL DATA

**MBMP
MBMR
MBMC
MCMP**

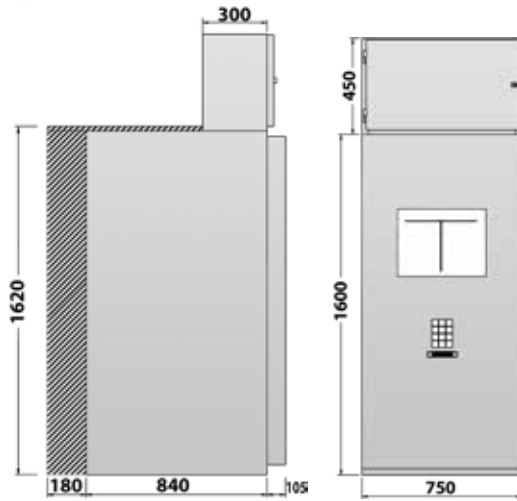

**ICBV
ILCBV**

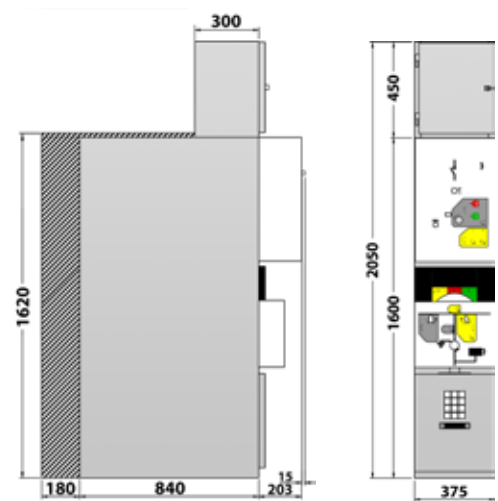

**ICB
ICBR
ICBLT
SCB
SCBR
SCBLT**

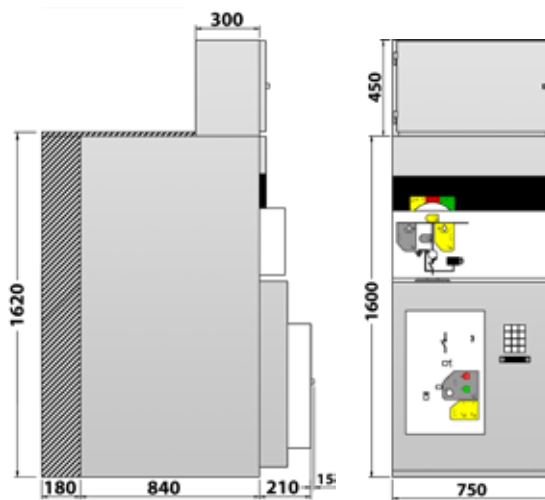

**2ICB
2MCB**

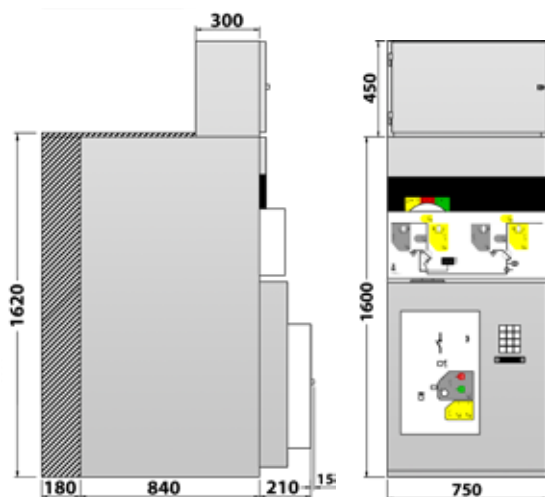

OPERATION SEQUENCES

UNITS OPERATING SEQUENCES



Qr Code usage instructions:

Download the right application from you device store to read QR-Code marks.

Start Application.

Point your device camera to the QR Code.

Multimedia information will be downloaded directly to your device.



TPS - SM - LT Op. Sequences

The video shows the switch operations sequences of the LT Operating Mechanism mounted on a SM unit.



TPS - FS - 3D Op. Sequences

The video shows the switch operations sequences of the 3D Operating Mechanism mounted on a FS unit.

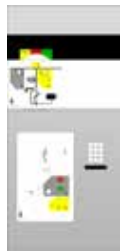

TPS - ICB - TCB Op. Sequences

The video shows the CB and Switch operations sequences of the NL and TCB Operating Mechanisms mounted on a ICB unit.



TPS - ICBV - TCB Op. Sequences

The video shows the CB and Switch operations sequences of the LT and TCB Operating Mechanisms mounted on a ICBV unit.



TPS - ILCBV - TCB Op. Sequences

The video shows the CB and Switch operations sequences of the LT and TCB Operating Mechanisms mounted on a ILCBV unit.



SEL

VIA AMENDOLA 51035 LAMPORECCHIO (PT) ITALY

TEL. +39 **0573.800.51**

FAX +39 **0573.803.110**

WEB SITE: WWW.SEL-ELECTRIC.COM

E-MAIL: INFO@SEL-ELECTRIC.COM

Our policy is one of continuous development. Accordingly the design of our products may change at any time. Whilst every effort is made to produce up to date literature, this brochure should only be regarded as a guide and is intended for information purposes only. Its contents do not constitute an offer for sale or advise on the application of any product referred to in it. We cannot be held responsible for any reliance on any decisions taken on its contents without specific advice.